



RFxpert

User Manual

v4.2.3.12

RFxpert™

Notices

© EMSCAN Corporation

No part of this user manual may be reproduced in any form or by any means (including but not limited to electronic storage and retrieval or translation into a foreign language) without prior consent from EMSCAN Corporation as governed by Canada and international copyright laws.

Trademark Acknowledgements

Adobe Acrobat ® and Reader ® are U.S. registered trademarks of Adobe Systems Incorporated.

Windows ® is U.S. registered trademarks of Microsoft Corporation.

Warranty

The material contained in this user manual is provided “as is” and is subject to being changed, without notice, in future editions. Further to the maximum extent permitted by applicable law, EMSCAN disclaims all warranties, either expressed or implied, with regard to this user manual and any information contained herein, including but not limited to the implied warranties of merchantability and fitness for a particular purpose. EMSCAN shall not be liable for errors or for incidental or consequential damages in connection with the furnishing, use, or performance of this document or any information contained herein. Should EMSCAN and the user have a separate written agreement with warranty terms covering the material in this document that conflict with these terms, the warranty terms in the separate agreement shall control.

Safety Notices

Caution

A CAUTION notice denotes a hazard. It calls attention to operating procedure, practice, or the like that, if not correctly performed or adhered to, could result in damage to the product or loss of important data. Do not proceed beyond a CAUTION notice until the indicated conditions are fully understood and met.

Warning

A WARNING notice denotes a hazard. It calls attention to an operating procedure, practice, or the like that, if not correctly performed or adhered to, could result in personal injury or death. Do not proceed beyond a WARNING notice until the indicated conditions are fully understood and met.

Warranty

EMSCAN warrants to its customers that any RFxpert from the date of delivery will perform substantially in accordance with the specifications provided, when properly installed, operated, and maintained for the duration of the warranty purchased by the customer.

During the warranty period, EMSCAN will at its option either repair or replace, at no charge, RFxpert product or parts thereof which do not perform in accordance with the specifications.

For warranty service or repair, RFxpert must be returned to EMSCAN. EMSCAN will pay shipping charges to and from EMSCAN if Buyer is under warranty, original or extended. You can extend your original warranty by purchasing option 3000-0122 (Additional One Year Customer Care Package).

Is your document and RFXpert software up-to-date?

Periodically, we update the documents and RFXpert software. You may access documents from the links below:

User manual: <https://www.emscan.com/products/antenna-testing/resource-centre/>

Software release notes: <https://www.emscan.com/products/antenna-testing/resource-centre/>

Technical bulletin: <https://www.emscan.com/products/antenna-testing/resource-centre/>

FAQ: <https://www.emscan.com/products/antenna-testing/rfx2/>

RFXpert software is not publicly available on EMSCAN web site. To receive e-mail notifications for software updates, please send an e-mail to rfxupdate@emscan.com

Disclaimer 1

(not applicable to USA, Canada and those countries* that have adopted CE marking)

The RFXpert RFX2 / RFX were tested with a CE marked and certified power supply (AC/DC Adapter) conforming to all relevant requirements of EMC Directive 2014/30/EU. No Power supply will be supplied with the RFXpert RFX2 / RFX at the time of purchase. User must power the RFXpert RFX2 / RFX by a CE marked Power Supply bearing local standard conformity logo and comply with following specifications:

- DC output voltage: 12VDC +/-5%
- Minimum DC output current: 3.0A
- 12V Connector: 2.5 x 5.5 x 9.5mm Straight Barrel type, Center positive

Failure to use a Power Supply with the above specifications, EMSCAN cannot guarantee the EMC compliance, safety or proper operation of the respective product and will void the warranty.

(*Austria, Belgium, Denmark, Finland, France, Germany, Greece, Ireland, Italy, Luxemburg, the Netherlands, Portugal, Spain, Sweden, United Kingdom, Iceland, Liechtenstein, Norway, Estonia, Latvia, Lithuania, Poland, Czech Republic, Slovakia, Hungary, Slovenia, Malta, Cyprus, Bulgaria and Romania)

Disclaimer 2

When RFX is operating in continuous Scanning mode, under Electrical Fast Transients conditions as specified by IEC 61000-4-4 standard, RFX may experience disruption due to transient burst on the AC power line.

Subscribe to our social media channels to keep up-to-date

We regularly post new application notes, case studies, white papers, and application videos.

EMSCAN RSS feed: <https://www.emscan.com/news-events/>

EMSCAN YouTube channel: <https://www.youtube.com/user/emscancorporation>

EMSCAN LinkedIn page: <https://www.linkedin.com/company/emscan-corporation>

EMSCAN Twitter page: <https://twitter.com/emscancorp>

Table of Contents

- Technical Support** [6](#)
- About RFXpert** [7](#)
- Component Checklist, PC and Software Requirements** [8](#)
- Minimum System Requirements** [8](#)
- Connection Overview** [9](#)
- Option and Accessories** [11](#)
- Quick Installation and Checklist** [14](#)
- Hardware Setup and Software Installation** [18](#)
 - Hardware Setup [18](#)
 - Software Installation [20](#)
 - Guidelines for Setup [26](#)
 - Verify RFXpert and PC Connection [27](#)
- How to Position AUT/DUT for Exceptional RFXpert Accuracy** [28](#)
- Menu Bar** [33](#)
- Nodes** [37](#)
 - How to Add a Scan Type and Select Scan Settings? [37](#)
 - How to Rename a Node? [37](#)
 - How to Copy and Paste a Node or a Node Setting? [38](#)
 - How to Export Data to Excel or Copy an Image? [39](#)
 - How to Add Note to a Node? [39](#)
- Viewing Scan Results** [40](#)
 - Near-Field Views [40](#)
 - Far-Field Views [41](#)
 - Data List / Charts Window [42](#)
 - Modifying “Data list” Content [43](#)
 - Preference [45](#)
 - Radiation Pattern Correction [46](#)
 - Holographic Projection [47](#)
 - Report Generator [48](#)
- Scan Types** [49](#)
- Fixed Frequency Scan** [50](#)
- Swept Frequency Scan** [53](#)

Table of Contents

S_{11} Scan	55
Base Station Emulator Scan	56
Multi Co-planar Scan	58
Near-Field Measurement Mask	62
PRAD Offset Table	64
Comparing Scan Results	66
Correlation	66
Fixed Frequency Scan Comparisons	67
Swept Frequency Scan Comparisons	70
S_{11} Scan Comparisons	70
Aggregate Node	72
Application Notes: Network Analyzer for S_{11} and Swept Frequency Scans	74
Network Analyzer Calibration: S_{11} and Swept Frequency Scans	74
Copper Mountain S5048 and PLANAR 808/1 Setup	75
Frequently Asked Questions (FAQ)	76
Appendix	83
Comparing with a Golden Sample from Another Project	83
Creating Comparisons for Over the Air Measurements	84
Connecting Power Meter and Network Analyzer	85
Power Meter Profile	85
Power Metering in Real-Time	87
Working with Unsupported Power Meters	88
GPIB Instrument Connection (HP 8714ES/ED or Agilent 8960)	88
Total Radiated Power (TRP) Measurements with Phantom Head + Hand Test Kit	90
Error Messages	92
Glossary (Summary of Far-Field Values)	102
Glossary (CTIA Parameters)	103
Regulatory Compliance	107
Safety and Regulatory Information	107
FCC Class B Notice	108
CE mark	109
Notes	110

Technical Support

To help us provide fast and seamless technical support, kindly gather the following information and contact Technical Support as instructed further below.

- Serial number of your RFXpert. RFXpert serial number is located at the bottom of the scanner.

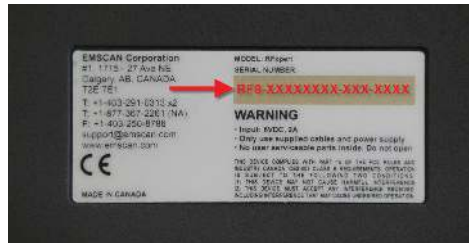

- Software release version. Start RFXpert software and click **System** to access to scanner ID, software and firmware versions:

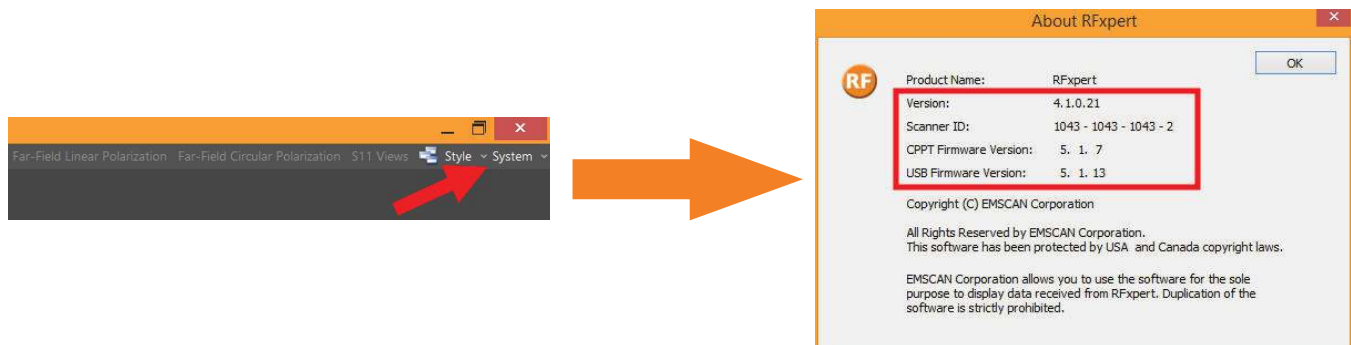

- Windows OS
- Agilent IO or Keysight IO version
- IO screenshot of the connected network analyzer, power sensor or base station emulator
- Model and firmware level of the network analyzer, power sensor or base station emulator
- Connection type to the network analyzer, power sensor or base station emulator from your PC: USB or Ethernet (then IP address pair) or USB+GPIB
- Project file *.rfx
- Power profile *.prof
- Description of the problem including screen shots and videos

Toll Free (North America Only): +1-877-367-2261
International: +1-403-291-0313 ext 2
Fax: +1-403-250-8786

info@emscan.com
www.emscan.com

EMSCAN Corporation
#1, 1715 27th Avenue N.E. Calgary, Alberta, Canada T2E 7E1

About RFxpert

RFxpert is a fast, easy to use, and accurate measurement system to assist designers who are developing and evaluating single or multi-antenna structures including MIMO solutions.

RFxpert measures the amplitude and phase of very-near-field magnetic emissions and uses these data to calculate and display far-field patterns and other parameters in real-time.

There are two models of RFxpert. They are identical in functionality but differ in size of the scan area:

RFX maximum radiator size: 10 cm x 16 cm

RFX2 maximum radiator size: 32 cm x 32 cm

- RFxpert can be used to evaluate either standalone (i.e. passive) antennas or antennas that are embedded in wireless devices (i.e. active antennas).
- RFX2 can be used for characterization of large antennas (e.g. phased arrays) up to 2.32 m x 2.32 m in size with the standard RFxpert application and can be used to characterize antennas of any size with an additional separate software application.
- RFX2 can be used with the [Phantom Head + Hand Test Kit \(page 90\)](#) to test mobile phones as per CTIA standards (**available only for the RFX2 models**).
- RFxpert can be used with a few specific models of [Network Analyzers \(https://www.emscan.com/products/antenna-testing/rfx2/\)](https://www.emscan.com/products/antenna-testing/rfx2/) to display S_{11} and then calculate antenna gain and efficiency.
- RFxpert can also be integrated with a few [Base Station Emulators \(https://www.emscan.com/products/antenna-testing/rfx2/\)](https://www.emscan.com/products/antenna-testing/rfx2/) to test cell phones.
- RFxpert calculates the right and left hand circularly polarized patterns and displays axial ratio patterns.
- RFxpert can be integrated into virtually any automated test bed and production line by using DLL programming. Test scripts can be written to define sequences of measurements integrating Network Analyzers or Base Station Emulators.
- RFxpert's golden sample comparison tool is ideal for sample lot testing and product verification for wireless service providers or for manufacturing.

When an RFxpert is connected to the PC, the RFxpert application detects the model and the client software brings up the proper scan area. In this user manual, RFX pictures and screen shots are used except where unique RFX2 features are concerned.

The purpose of this user manual is to provide general information and instructions regarding the operation of RFxpert. If you have further questions or require further assistance, please contact [EMSCAN](#) Technical Support.

Component Checklist, PC and Software Requirements

Components Supplied with the System

1. RFXpert Scanner (integrated antenna board and processing electronics)
2. Universal Power Supply (Disclaimer: AC/DC adaptor is included only for Canada, US and European Union countries. For other countries please procure and use a power supply with the following specs for RFXpert RFX or RFXpert RFX2:
 - DC output voltage: 12VDC +/-5%
 - Minimum DC output current: 3A
 - Connector: 2.5 x 5.5 x 9.5mm Straight Barrel Type, Center Positive
 - Must be compliant to local regulations



Failure to use a power supply with the specs described above for respective products will void the warranty.

3. USB Cable: to connect the PC (laptop or desktop) to RFXpert



4. RFXpert USB Drive: includes the RFXpert software installation program, User Manual



5. Foam spacer: This electromagnetically-transparent foam spacer is to be placed between the scanner and the AUT to reduce the coupling effects and improve the accuracy of efficiency measurements. The separation value must be set in the software ([separation tab page 52](#)) when using this foam spacer. Please refer to [page 28](#) on how to position AUT/DUT for exceptional RFXpert accuracy



Minimum System Requirements

RFXpert client software runs on Windows 10, Windows 8, and Windows 7 OS platforms

Minimum Recommended PC Features:

1. Processor Type: Intel Core
2. Processor Speed: 3.2 GHz
3. RAM: 1 GB
4. Graphic Card: 256 MB with OpenGL graphic enabled
5. USB Ports: at least 1 USB, 2.1 protocol support preferred
6. Monitor/Screen resolution: Operating in wide screen mode (aspect ratio greater than 4:3) is recommended for best viewing

Components Software Requirements

1. Microsoft .NET Framework
2. Keysight IO Libraries Suite

RFXpert client software installation process covers above mentioned software installations.

Connection Overview

RFX Scanner



Item Number	Description
1	Universal power supply port
2	USB connection port

Caution:
The surface of the scanner is made of Gorilla® glass. It may shatter if a sharp object is dropped from a distance.

RFX2 Scanner

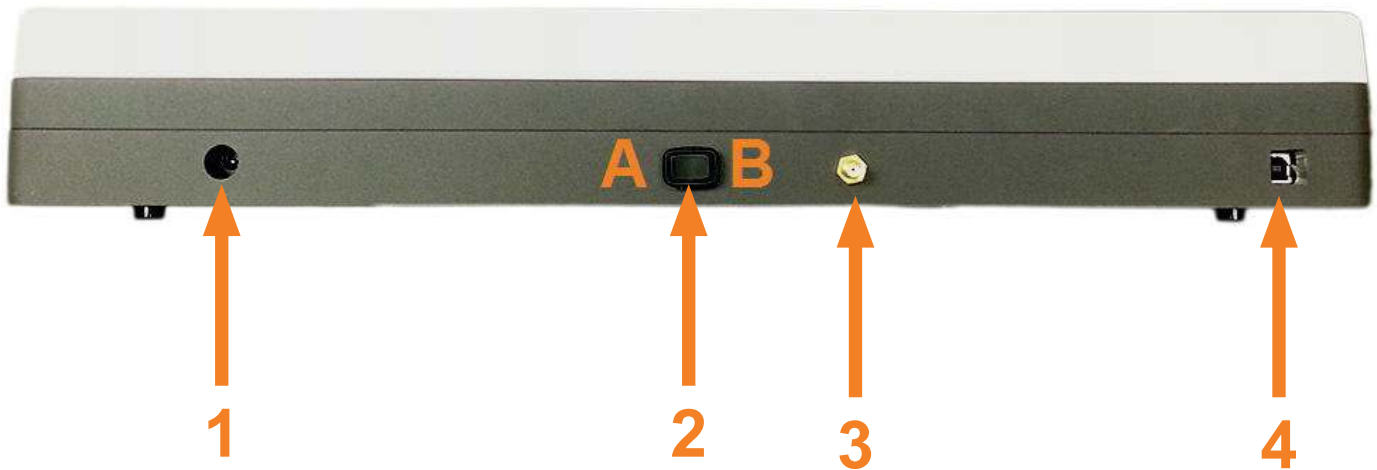

Item Number	Description
1	Universal power supply port
2*	Phase Switch Position A: Internal phase. This is used for regular scanning. Position B: External phase. This is used for Multi Co-Planar (page 58) scanning and Correlation (page 66) .
3*	Phase Port
4	USB connection port

*Available only on RFX2 models shipped after July 2013. Contact us for a retrofit.

Caution:

The surface of the scanner is made of Gorilla® glass. It may shatter if a sharp object is dropped from a distance.

Option and Accessories

Contact [EMSCAN](#) or your dedicated EMSCAN Sales Associate to place an order.

Part Number	Description
3000-0815	Hard Transit Case RFX with customized insert
3000-0818	Hard Transit Case RFX2 with customized insert
3000-0817	Large Hard Transit Case to carry FieldFox and RFX with customized insert
3000-0303	CP Analysis: Software application for circular polarization Axial Ratio (AR), Left-Hand Circular Polarization (LHCP) and Right-Hand Circular Polarization (RHCP) measurements and graphs
3000-0300	BSE Function: Programmable interface for remote control of a Base Station Emulator to enable power and pattern measurements at a single frequency or series of frequencies at a set interval
3000-0306	Phantom Head+Hand Test Kit as per CTIA Test Plan for Mobile Station Over the Air Performance 3.2.1 for RFX2 that includes <ul style="list-style-type: none"> - Half-head derived from full head specifications - PDA grip right hand for smartphone - Palm spacer and alignment tool - Test fixture for holding RFX2 including sliding/rotating head+hand fixture with material properties as per CTIA compliant fixtures
3000-0306H	Phantom Head+Hand Test Kit as per CTIA Test Plan for Mobile Station Over the Air Performance 3.2.1 for RFX2 that includes <ul style="list-style-type: none"> - Half-head derived from full head specifications - PDA grip hand for smartphone - Palm spacer and alignment tool
3000-0307	Additional CTIA Hand as per Appendix C of CTIA Test Plan for Mobile Station Over the Air Performance 3.2.1. Includes Palm Spacer and Alignment Tool. Select one of: <ul style="list-style-type: none"> - Monoblock grip - Fold Grip - Narrow Data Grip
3000-0819	RF Source: Stable programmable power source from 300 MHz to 6 GHz that fits into the shielded box of the 3 GPP RAN4 MIMO Antenna. <ul style="list-style-type: none"> - Maximum output power: +10 dBm - Repeatability of output power level: +/-0.2 dBm - Battery power: 2-3 hours - Enclosure: 121 mm x 78 mm x 26 mm - Standalone operation: Front panel controls

About RFXpert
Option and Accessories

3000-0820	<p>High Frequency Basic MCP Jig: Set of tiles, absorber blocks and rolling rig to enable high frequency 1.3 GHz to 6 GHz multiple-co-planar measurements with RFX2. Includes</p> <ul style="list-style-type: none"> - 6 tiles with positioning holes for a 2 x 3 set - 6 absorbers: 4 RFX2 blocks and 2 standard blocks for test above 1 GHz - 1 rolling rig for RFX2 with positioning wheels
3000-0824	<p>High Frequency MCP Jig Expansion: Two tiles and two square absorber blocks for test > 1.3 GHz</p>
3000-0825	<p>Low Frequency Basic MCP Jig: Set of tiles, absorber blocks and rolling rig to enable low frequency 600 MHz GHz to 6 GHz multiple-co-planar measurements with RFX2. Includes</p> <ul style="list-style-type: none"> - 6 tiles with positioning holes for a 2 x 3 set - 6 absorbers: 4 RFX2 blocks and 2 standard blocks for test above 600 MHz - 1 rolling rig for RFX2 with positioning wheels
3000-0826	<p>Low Frequency MCP Jig Expansion: Two tiles and two absorber blocks for test > 600 MHz</p>
3000-0129	<p>NRE Charge for custom development of a VNA driver for any network analyzer. Customer to loan specific network analyzer for 2 weeks.</p>
3000-0130	<p>NRE Charge for custom development of a VNA driver for any network analyzer. Equipment rental included provided it is available from rental companies.</p>
3000-0301	<p>NRE Charge for custom development of a BSE driver for any Base Station Emulator. Customer to loan specific equipment for 4 weeks.</p>
3000-0302	<p>NRE Charge for custom development of a BSE driver for any Base Station Emulator. Equipment rental included provided it is available from rental companies.</p>
3000-0305	<p>NRE Charge for custom development of a BSE driver for additional Base Station Emulator test application during the original driver development.</p>
3000-0960	<p>NRE Charge for custom development of a PM driver for any power meter. Customer to loan specific power meter for 2 weeks.</p>
3000-0961	<p>NRE Charge for custom development of a PM driver for any power meter. Equipment rental included provided it is available from rental companies.</p>
3000-0121	<p>RFXpert 3 GHz to RFXpert 6 GHz upgrade</p>
3000-0122	<p>Additional one year Customer Care Package. Includes:</p> <ul style="list-style-type: none"> - Parts & labour - Software updates - Free shipping to factory for repair and return - Same day technical support - Two 30 minute web training sessions per year - Back-up unit free of charge - 10% discount on new software applications

About RFxpert
Option and Accessories

3000-1610	<p>Calibration Assurance Plan for the RFX and RFX2 / Return to EMSCAN / 3 years</p> <ul style="list-style-type: none"> - Annual single calibration event included - When purchased with the unit or combined with a Customer Care Package of similar duration
3000-1611	<p>Calibration Assurance Plan for the RFX and RFX2 / Return to EMSCAN / 5 years</p> <ul style="list-style-type: none"> - Annual single calibration event included - When purchased with the unit or combined with a Customer Care Package of similar duration
3000-0900	<p>On-site installation and customer training per day. PAYABLE IN ADVANCE. Cost of instructor's travel and accommodation additional (inside continental North America p/n 3000-0902 or outside continental North America p/n 3000-0901). Scheduling dates to be committed only by EMSCAN. Sales person to indicate on the P.O. customer's preferred dates. EMSCAN to finalize all course scheduling and related arrangements with customer and EMSCAN Sales Representative or Distributor. Training sessions require a minimum of 4 weeks to schedule. Maximum number of participants is 10; participants are to bring their own EMSCAN equipment.</p>
3000-0901	<p>Trainer's travel, accommodations and expenses for travel outside the Continental USA and Canada. PAYABLE IN ADVANCE.</p>
3000-0902	<p>Trainer's travel, accommodations and expenses for travel within the Continental USA and Canada. PAYABLE IN ADVANCE.</p>
3000-0903	<p>Training at EMSCAN's Education Center per participant per day. PAYABLE IN ADVANCE. EMSCAN will provide equipment for the hands-on training, materials and lunch each day. Course scheduling will be determined based on a minimum of 3 confirmed registrants. Participants are responsible for their own travel and accommodation expenses. Every effort will be made to customize the course curriculum to meet participant needs.</p>

Quick Installation and Checklist

1. Click [here \(http://www.keysight.com/en/pd-1985909/io-libraries-suite?nid=-33330.977662.00&cc=US&lc=eng\)](http://www.keysight.com/en/pd-1985909/io-libraries-suite?nid=-33330.977662.00&cc=US&lc=eng) to install the latest version of the Keysight IO Libraries Suite
2. Install the RFPert software application by double clicking on the Setup application icon. The application must always be installed on the C: drive.
3. As long as the device under test is emitting, connect the PC and RFPert scanner as per the diagram below; no other equipment is required.

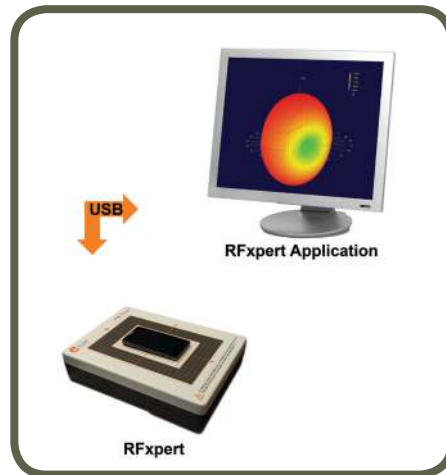

4. If you are testing a passive antenna, connect PC, RFPert scanner, network analyzer and optionally power sensor as per the diagram below. The power meter is used to measure the power source profile of the VNA, cable and connector up to the antenna under test for the test frequency range in order to obtain accurate gain and efficiency results.

Compatible network analyzer and power meters with the right hardware, firmware and software versions can be found at: http://www.emscan.com/rfpert/RFx_supportedVNA.cfm

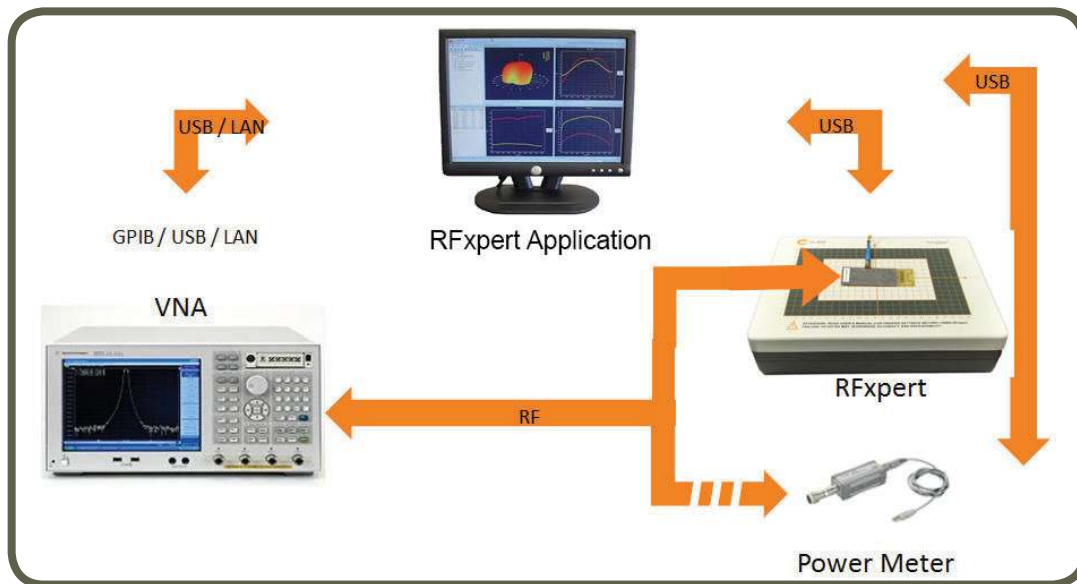

About RFXpert

Quick Installation and Checklist

5. If you are testing a mobile phone or cellular based device, connect the PC, RFXpert scanner and base station emulator as per the diagram below. Ensure that the BSE can call the phone by manually initiating a call. Test this connection with the phone on the RFXpert scanner so that the proper over the air path losses are taken into account.

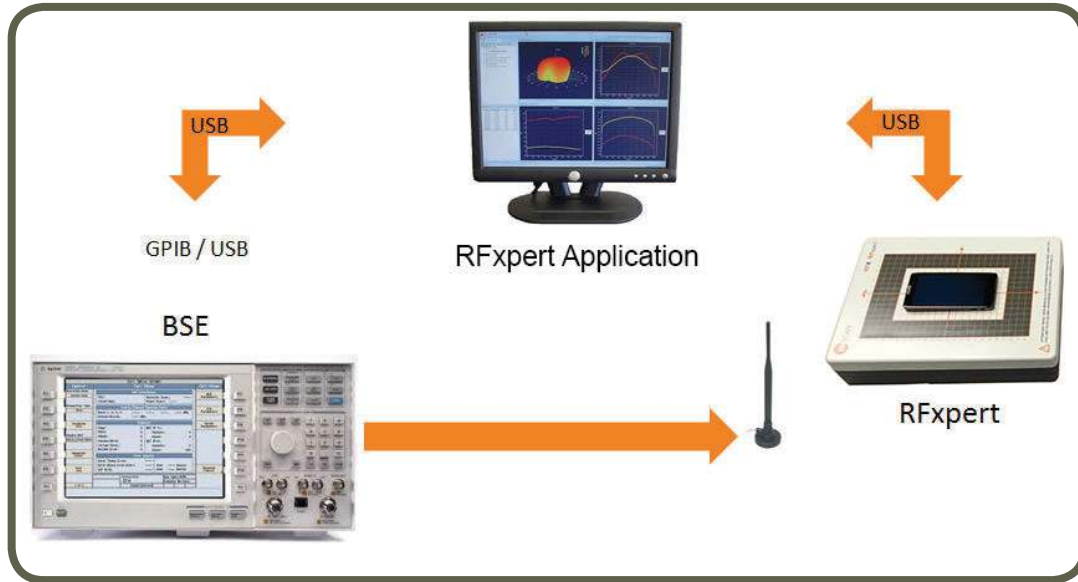

6. Install the RFXpert USB driver
Go to Windows' Device Manager
Expand "USB Custom Driver" and look for RFXpert USB Driver 2014
If it says 2010 or if there is a yellow triangle, right click and select Update driver and then browse to the "EMSCAN RFXpert USB Driver" folder in the install folder on your CD, hard disk or key.
Click on the "EMSCAN RFXpert USB Driver" folder and press OK.
Follow the installation steps.

Note that you may have to repeat this procedure if you connect the USB cable between the RFXpert and the PC to another USB port at another occasion. Note as well that not all USB ports are equal; some are less than others and may not work with the RFXpert. Try various ports until you find one working properly.

The RFXpert driver is a third-party Microsoft approved driver. If the installation fails, you must disable the third-party driver enforcement of Windows 8 and 8.1 as follows:

Windows 8.0

On the side START bar, click on "Settings"
Click on "Change PC settings"
In PC Settings, click on "General"
Scroll down to "Advanced startup"
Click on "Restart now"
In "Choose an option", click on "Troubleshoot"
In "Troubleshoot", click on "Advanced options"
In "Advancedoptions", click on "Startup Settings"
In "Startup settings", click on "Restart"
In "Startup settings", press number 7 on your keyboard to select "Disable driver signature enforcement"

Windows 8.1

On the side START bar, click on “Settings”

Click on “Change PC settings”

In PC settings, click on “Update and recovery”

In “Update and recovery” select “Recovery”

In “Recovery” go to “Advanced startup”

Click on “Restart now”

In “Choose an option”, click on “Troubleshoot”

In “Troubleshoot”, click on “Advanced options”

In “Advanced options”, click on “Startup Settings”

In “Startup settings”, click on “Restart”

In “Startup settings”, press number 7 on your keyboard to select “Disable driver signature enforcement”

7. If you are connecting to a network analyzer using an USB cable, go to Step 8.

If you are connecting to a network analyzer using an Ethernet crossover cable:

Set your network analyzer to the static IP address 172.16.1.148/255.255.0.0

For the N9912A demo unit at A.08.15

Press hard key System, then soft keys System Configuration / More / LAN / Edit

Set your PC with static IP address 172.16.1.99/255.255.0.0

Best is to set it up in Alternate Configuration in the Local Area Connection Properties / Internet Protocol Version 4 (TCP/IPv4) / Properties path

8. Open Keysight IO Libraries Suite

Look at the bottom right of the Keysight IO window and see if it says 32-bit Keysight VISA is Primary

If it is not, go to Programs and Features / Select Keysight IO / Change / Modify / Select PRIMARY

If you are connecting to a network analyzer using an USB cable, make sure the equipment shows under USB0 with a green check mark.

If you are using an Ethernet cable, delete all previous 172.16.1.148 connections under the LAN (TCPIP0) menu.

Keysight IO is good at auto-discovering and configuring. If it is connected properly you will see in the bottom section Messages the following two lines:

Instruments are already discovered and configured

User interface session started

If there is a connection issue, mostly with LAN, select Manual Configuration and then LAN Instrument

In Set LAN Address / Hostname or IP Address:

Enter the IP address 172.16.1.148

In Verify Connection

Click on Test this VISA Address

Then click on Accept

A green check mark should be next to the IP address 172.16.1.148 under the LAN (TCPIP0) menu branch.

About RFPert

Quick Installation and Checklist

If there is still no connection, disable your PC firewall or set it up to allow traffic to/from 172.16.1.148 and repeat the steps above.

Once connected, set the analyzer as a favorite. Click on the grey star and it will turn yellow.



9. Close Keysight IO

10. Open the RFPert application and get scanning! See User Guide for operations.

If your RFPert still does not work, contact us by e-mail at support@emscan.com or call +1-403-291-0313 ext. 2

Hardware Setup and Software Installation

Hardware Setup

- Connect B-end of the USB cable to the USB port on RFXpert



- Connect A-end to any USB port on the client computer



- Plug the included power supply into the power supply port of RFXpert and into the appropriate 100/240V wall socket.



Warning: Use ONLY the 6 VDC power supply that is supplied with RFX
Use ONLY the 12 VDC power supply that is supplied with RFX2

Getting Started Hardware Setup



RFExpert Setup Showing Power and USB Cables
(RFX2 model shown in the picture)

Getting Started

Software Installation

Software Installation

1. Plug-in the RFXpert USB drive. Select the software folder and double click on Setup.exe file  setup
2. When you are prompted “Do you want to allow the following program from an unknown publisher to make changes to this computer” click Yes
3. Below screen will be displayed

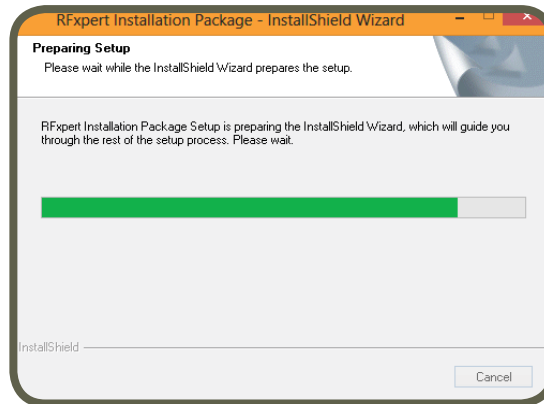

4. Click Accept



5. Click Next



Getting Started Software Installation

6. Check I Agree and click Next

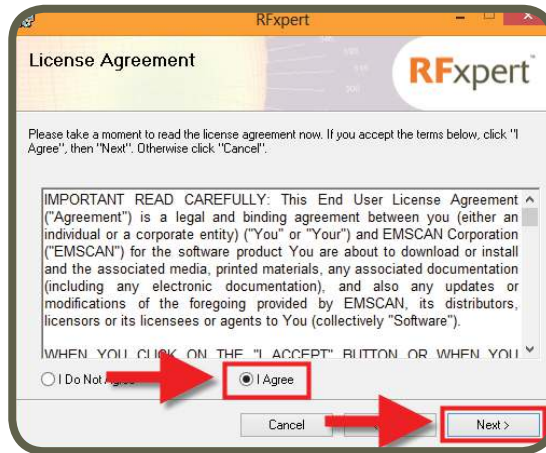

7. Select installation folder, check Everyone or Just me and click Next



8. Click Close



Getting Started

Software Installation

9. If Keysight IO Libraries Suite is not installed on your PC, the screen below will be displayed. You need an internet connection for this installation. Once you establish an internet connection click OK.

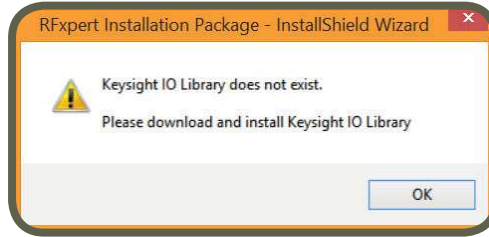

10. You will be redirected to the Keysight website and the Keysight IO Libraries Suite installation package will be downloaded. Once the download is complete, open Downloads folder on your computer and double click on installation package.



11. While the software is installing, the screen below will be displayed at the same time.



12. Click "Install now" under IO Libraries Suite and click Next

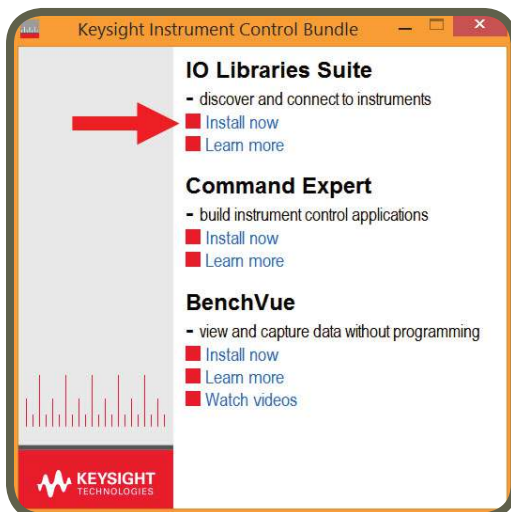

Getting Started Software Installation

13. Select Agree and click Next

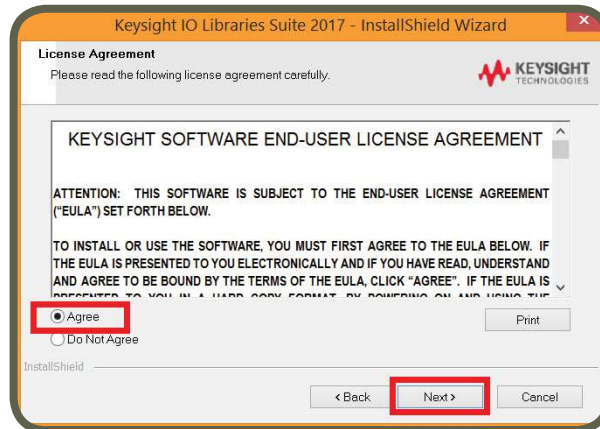

14. Select Typical and click Next

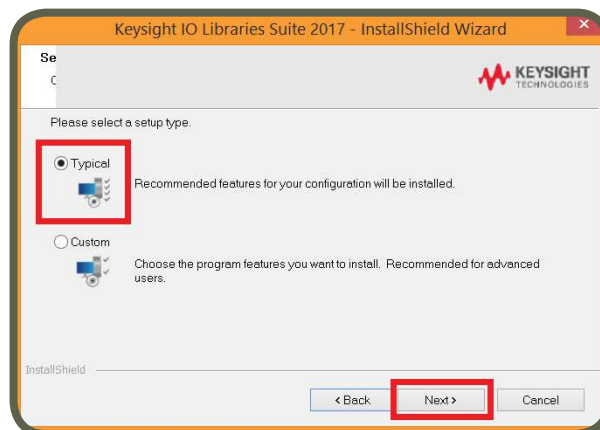

15. Check or uncheck "Automatically share anonymous diagnostic and usage information" and click Next

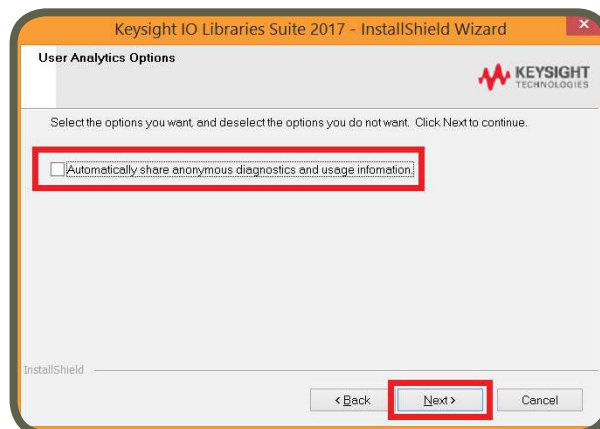

Getting Started Software Installation

16. If Microsoft Visual C++ is not installed on your PC the screen below will be displayed. Click Install

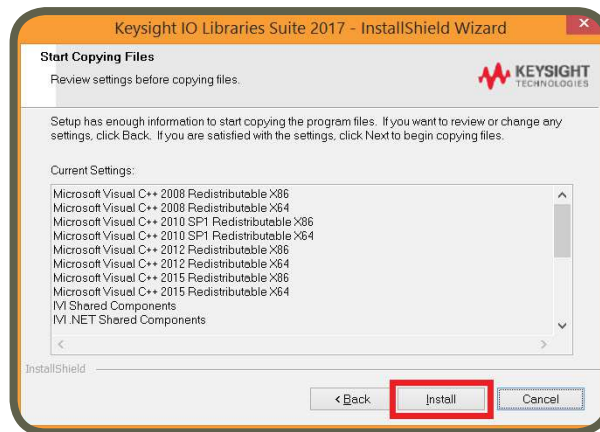

17. While the software is installing, the following screen will be displayed.

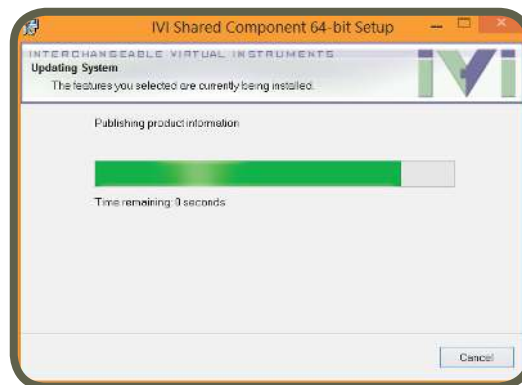

18. Click on Finish

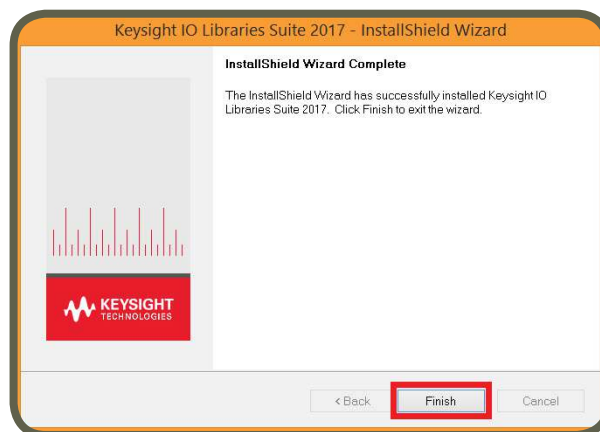

19. Verify that the Keysight IO Libraries Suite is set as primary VISA.

- Double click on the IO icon on the right corner of your screen



Getting Started Software Installation

- Look at the bottom right of the IO window and confirm it displays Keysight VISA is primary

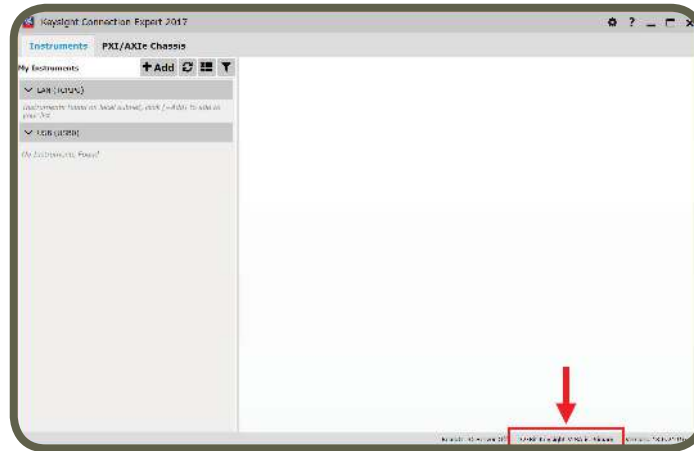

- If it doesn't, go to Control Panel/Programs/Select Agilent IO/Change/Modify/Select PRIMARY [in Windows 7 or equivalent path for other Windows OS]. Select Modify and click Next

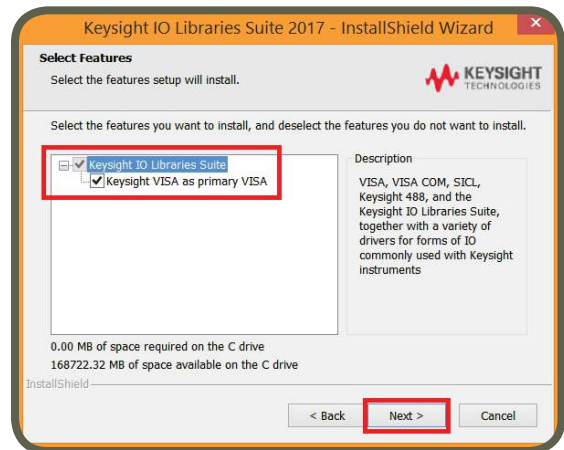
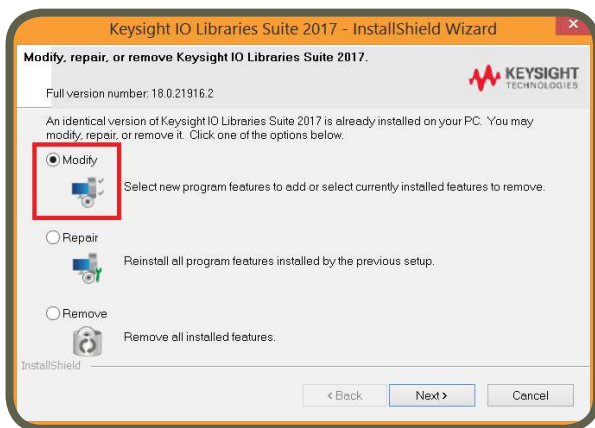

- Check Keysight Visa as primary Visa and click on Next and then click Finish

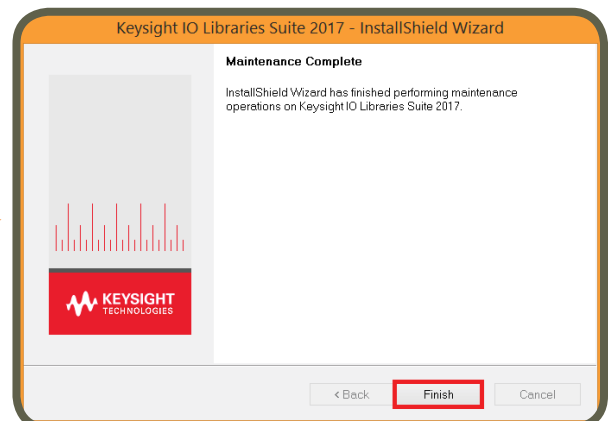

Guidelines for Setup

A proper setup is more critical for frequencies below 1 GHz but is important for measurements done with RFXpert at higher frequencies as well. The following guidelines will help reduce the effect of the environment on the measurement results.



1. Platform on which to place the RFXpert
 - Wooden desk is the best possible platform.
 - Metal desks may affect the repeatability of the test results. If you have no other option than a metal desk then please make sure that once you place RFXpert on the desk, you don't change its position for the consecutive tests.
 - Anti-static mats are conductive and may affect the repeatability of the test results. Please avoid using antistatic mats under or around RFXpert. If you have no other option than using an antistatic mat then please make sure that once you place RFXpert on the mat, you don't change its position and you run tests in the same position.
2. Objects around RFXpert
 - Leave a minimum 30 cm distance between RFXpert and the objects around it.
 - Use wood / styrofoam to prop up the antenna or wireless device on RFXpert. Do not use metal.
 - There may be metal studs in walls. Keep a minimum 30 cm distance from the wall.
 - Desk frame can be made of metal. Keep RFXpert at least 30 cm away from any metal frame.
 - Make sure that cables (connection cables between RFXpert and PC) don't go over RFXpert. To minimize emissions from RF feeding cables, you can use ferrite beads.
3. Objects above RFXpert
 - Make sure you don't place RFXpert under metal shelves. Large metal reflectors above RFXpert may affect the repeatability. For example fluorescent lights are often hung in large metal boxes. Be cautious about placing RFXpert under these light fixtures.

Getting Started

Verify RFXpert and PC Connection

Verify RFXpert and PC Connection

Before starting your RFXpert application, please make sure that RFXpert is plugged into the USB port and is powered on.

Once RFXpert is connected, an orange USB icon  will be displayed on the taskbar. If there is no connection, a red USB icon  will be displayed. Alternatively, you can verify if the device is recognized properly by opening the “Device Manager” in the “Control Panel”. Under “Custom USB Devices” you should see “EMSCAN RFXpert © 2014”.

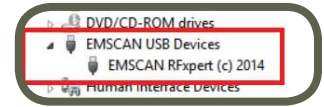

Once the device has been properly recognized you can start RFXpert application by double clicking  on your desktop. You can also launch the application from the Program Menu under EMSCAN tab.



The first time you start RFXpert application, it will ask you to update configuration file.

1. Click Yes

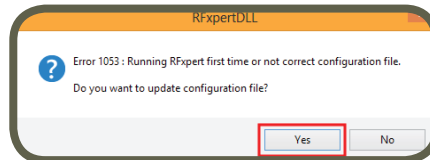

2. The following dialogue box will appear. The update takes about 2-3 minutes

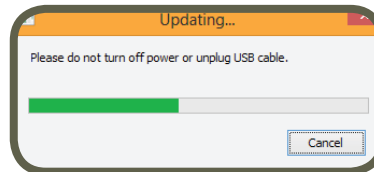

3. Once the update is complete, click OK

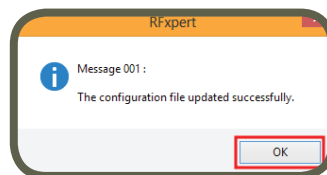

At this point a new scan can be created and run or existing data in the directory can be opened.

How to Position AUT/DUT for Exceptional RFxpert Accuracy

Proper positioning of the antenna under test (AUT) or active device under test (DUT, a device with an embedded antenna) on or above the lid of the RFxpert system is crucial to achieving exceptional RFxpert accuracy out of the box. Guidelines for an appropriate set-up are provided herein.

DUT refers to either AUT or DUT in this manual.

DUT that can be tested with the 2-sided RFxpert scan techniques can only be 2D (patch, planar etc.) or 2.5 D (rod, multi-layer, mobile phone etc. whereby one dimension, Z is small compared to the other two, X and Y).

There are 4 position parameters to manage:

1. Position of the emission
2. Direction of the emission
3. Separation of the antenna
4. Position of the cable

1. Position of the emissions

Emissions should be centered in the middle of scanner for the frequency under test. This is not always the physical centre of the DUT; for example the source of emissions will move up or down along a whip antenna depending on the frequency. Not only should the emissions be centered, the very-near-field emissions should be completely captured by the scanner and thus not extend beyond the edges of the scanner. This can be easily monitored using the Near-Field Views of the RFxpert.

In this example, the tablet is physically centered on the scanner (Fig. 1. a). At GSM 850 MHz (Fig. 1. b) the entire backplane of a tablet would radiate whereas at GSM 1900 MHz it could be the edge that radiates (Fig. 1 c). In addition, part of the GSM 1900 emissions are not captured by the scanner (Fig. 1. c). Hence, the tablet will have to be moved down the Y axis to be properly tested at GSM 1900.

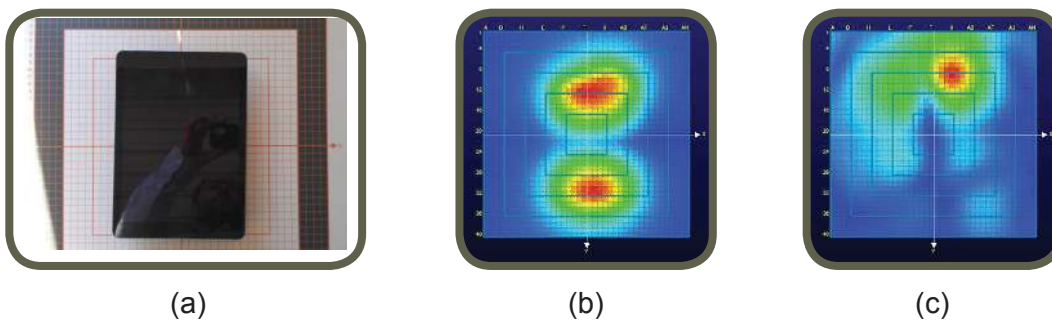

Fig. 1. (a) Tablet centered on the scanner (b) GSM 850 centered (c) GSM 1900 off centre

2. Direction of the emissions

The radiation of the DUT must be directed towards the surface of the RFxpert scanner. The DUT can usually be placed parallel to the surface of the RFxpert.

Placing the antenna flat along the surface is not always the best way to measure it. For example, a Vivaldi antenna which is an end-fire antenna should be placed with its wider ends onto the scanner as shown in Figure 2.

The best way to know how to position the DUT is to have some understanding of the antenna design but if nothing is known then a trial and error process can determine the main radiation direction.

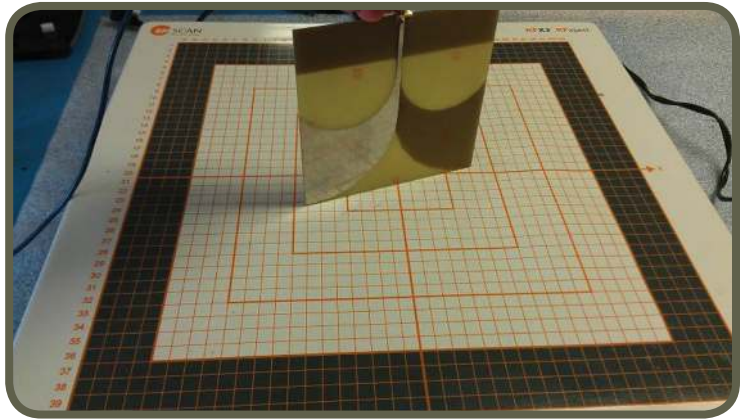

Fig. 2. Emissions directed toward the scanner

For omnidirectional antennas this is not as much a concern although some care should still be taken. For example, do not direct the null of a dipole into the scan surface.

3. Separation of the antenna: Physical elevation above surface of the lid

The major contributor to the inaccuracy of an RFxpert measurement, especially efficiency measurement, is the change that occurs in the radiation of the antenna as a result of its proximity to the scanner underneath the lid. This effect is often referred to as the “coupling between the RFxpert and the DUT” or “loading of the DUT by the RFxpert” and can be avoided by placing the DUT farther from the scanner. However, as the DUT is moved away from the scanner, the signal strength might dip below the 0 dB threshold and/or the very-near-field emissions might exceed the size of the scanner and thus not be captured properly. Also, the shape of the radiation pattern becomes more and more directive and less and less accurate as the DUT is moved away from the scanner. This is mainly because larger separation between the scanner and the DUT decreases the angle of validity of the predicted far-field pattern.

The effect of antenna separation on the radiated power and predicted efficiency is calibrated in the RFxpert software.

In any case, the radiating source of the DUT can never be higher than 115 mm from the lid for the RFX2 and 45 mm for the RFX.

S_{11} is the primary parameter to monitor when optimizing the position of an antenna. S_{11} , commonly referred to as the reflection coefficient (or its positive magnitude as return loss), is a measure of how much power is reflected from the antenna back to the source. A properly matched antenna has a small S_{11} and can hence receive most of the source power in order to radiate it. S_{11} can be monitored directly on the VNA connected to the antenna. It is also displayed on the RFxpert after an S_{11} Scan or during a Swept Frequency Scan.

Note that the difference in the power that is delivered to two antennas with return losses of -10 dB and -12 dB is only 4%.

A- Efficiency measurements

Place the DUT 1 inch/25 mm away from the scanner for all frequencies. Please use the foam spacer that is supplied with your unit.

Keep in mind the need for the very-near-field emission to be within the scanner outline as recommended in Section 1 above. This will decide whether the RFX is suitable for your DUT or if the RFX2 is required.

B- Pattern Measurements

Up to 1 GHz

Monitor S_{11} and try to lower the antenna as close as you can without significantly affecting S_{11} :

- For narrowband antennas, a shift in S_{11} resonant frequency of more than 1% is unacceptable but fortunately uncommon. For wideband antennas, the resonance shift is not critical unless measurement are done right at the band edge.
- It is recommended to maintain an S_{11} better than -5 dB, assuming the free space performance is also better than -5dB

Note: Depending on the initial/unloaded S_{11} , this limit might be lower. For example, if the initial S_{11} is -15 dB try to maintain an S_{11} of better than -8 dB at resonance.

When the S_{11} can't be measured, such as when testing an active device, a default value of 25 mm above the lid surface is a good rule of thumb.

Above 1 GHz

Monitor S_{11} and try to lower the antenna as close as you can without significantly affecting S_{11} :

- For narrowband antennas, a shift in S_{11} resonant frequency of more than 1% is unacceptable but fortunately uncommon. For wideband antennas, the resonance shift is not critical unless measurement are done right at the band edge.
- It is recommended to maintain an S_{11} better than -10 dB (unless the free space S_{11} is higher)

When the S_{11} can't be measured, such as when testing an active device, you can place the active device flat on the lid; zero elevation.

Setting the separation in the Node Settings

Once the antenna has been properly positioned above the lid, the distance between the surface of the lid and the antenna has to be set in the RFxpert application by the end-user. The RFxpert has no way of knowing if the amplitude of a signal is from a low powered antenna next to the lid or a higher powered one a few inches or centimeters away from the lid.

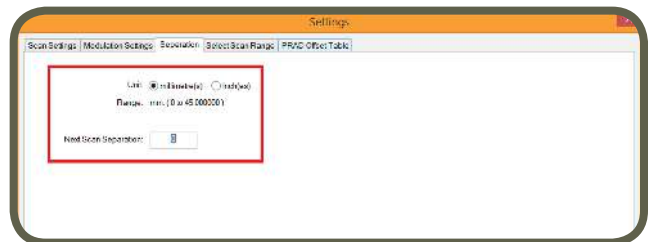

Fig. 3. Setting the separation value

Simply go to Node Settings and select the Separation tab as per the Figure 3. Then enter the proper value.

The good news is that if you forget to enter the separation value before the scan or made a mistake, you can enter the proper value after the scan and all the data will be adjusted.

While it is easy to figure out what is the distance from a patch or PCB antenna from the lid – it will be surface to surface – things are not always obvious for a device, a thicker antenna, a log-periodic antenna or a Vivaldi antenna for example.

In the case of a rod or whip antenna, like a monopole or dipole placed parallel to the lid, half of the diameter will be a good separation value.

In the case of a large device with an embedded antenna or a thick antenna where it is hard to tell the distance from the lid, it is best to lift the DUT as high as possible though no higher than 115 mm from the lid for the RFX2 and 45 mm for the RFX, as the error in the compensation of the separation will be relatively smaller the farther away you are; provided that the entire emission remains in the centre of scanner as mentioned previously. Then you want to focus on the antenna surface not necessarily the device surface. If there are multiple radiating surfaces such as in the thick patch example in Figure 4, it is best to choose the centre point of the structure, between the upper patch element and the ground plane above it.

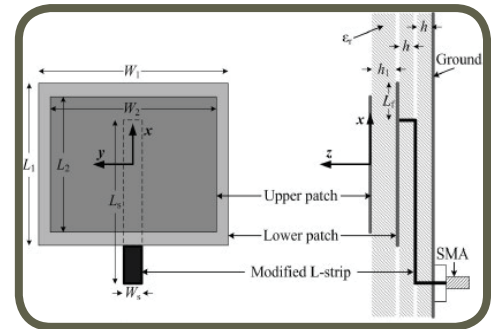

Fig. 4. Thick complex antenna

However, if you know which patch or maybe even the ground plane is emitting at what frequency, then do enter the exact distance.

In the case of a log-periodic antenna (Figure 5) or Vivaldi antenna (Figure 6), the separation is clearly frequency dependent. As the frequency increases the aperture will effectively move up to the narrower tip of the log-periodic antenna and to the thinner part of the “arms” of a Vivaldi antenna. You therefore place the antenna flat on its side first (Fig. 5. a) and the near-field view will allow you to actually see where the radiation is coming from at different frequencies (Fig. 5. b and c). Once you have this data, you can enter the elevation when you test such antenna properly, set vertically and emitting toward the scanner.

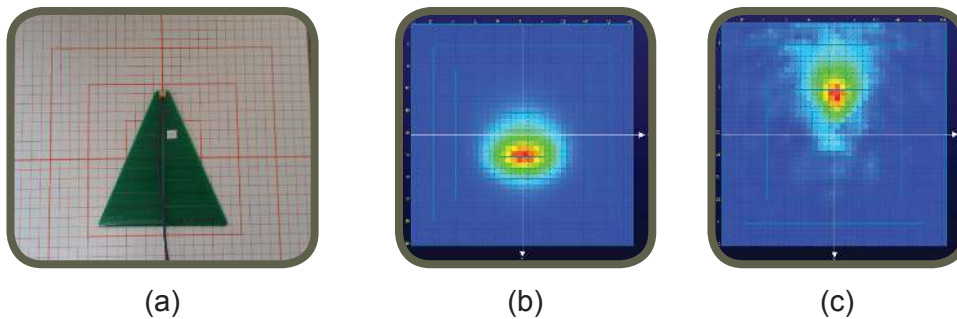

Fig. 5. (a) Log-periodic antenna on scanner (b) 1 GHz ~ 110 mm from end (c) 5 GHz ~ 0 mm from end

For example, at low frequencies (up to 1GHz) you would end up using 0 mm as separation but at high frequency like 6 GHz you might use an elevation equivalent to about half the size of Vivaldi antenna, 2 inches or about 50 mm for this model in the Figure 6.

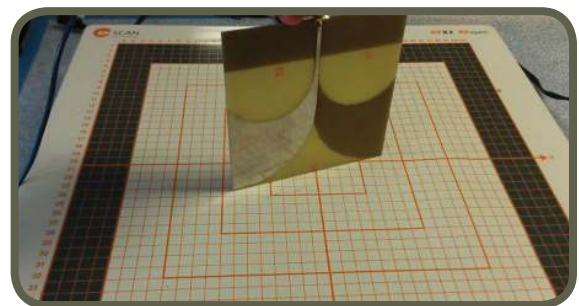

Fig. 6. Vivaldi antenna

4. Position of the cable

Back-fed is better in order to have the cable perpendicular to the lid. Use a right-angle connector if required as shown in the Figure 7 below.

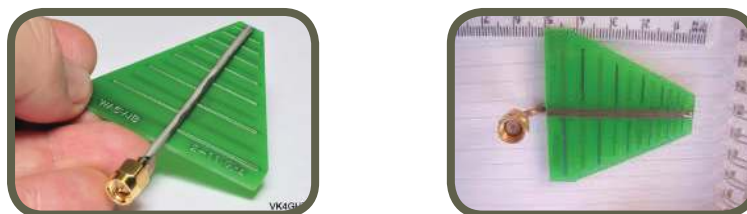

Fig. 7. Elbow connector as on the right is preferred

If the cable is along the surface of the lid, check the near-field results to see its impact as per the Figure 8 below.

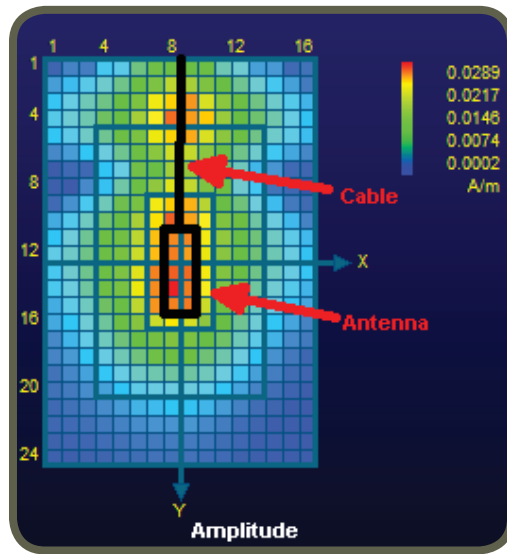

Fig. 8. Near-field emissions of the cable

If you use absorber material or ferrites as in Figure 9 or the mask function as in Figure 10, you can control or even eliminate the effect of the cable to get accurate far-field data of the DUT, not of the DUT and cable.

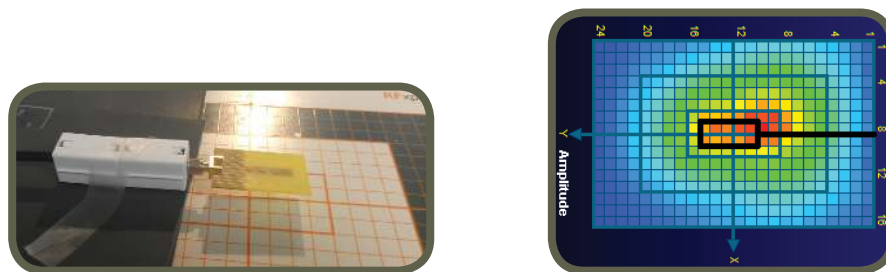

Fig. 9. Reduction of the cable emissions with ferrites

The mask feature can be found in the Node Settings / Select Scan Range as per the Figure 10 below. It should be used as a last resort as it is less effective as physically removing the emissions. By highlighting the probes underneath the parasitic radiation from the cable, the cable emission will not be taken in account in the far-field.

Conclusion

Properly positioning the antenna or device under test in the X Y Z coordinates above the RFxpert as explained above will result in outstanding measurement accuracy. And given the sub-second speed at which the measurements are taking place, your RFxpert will be a very effective tool.

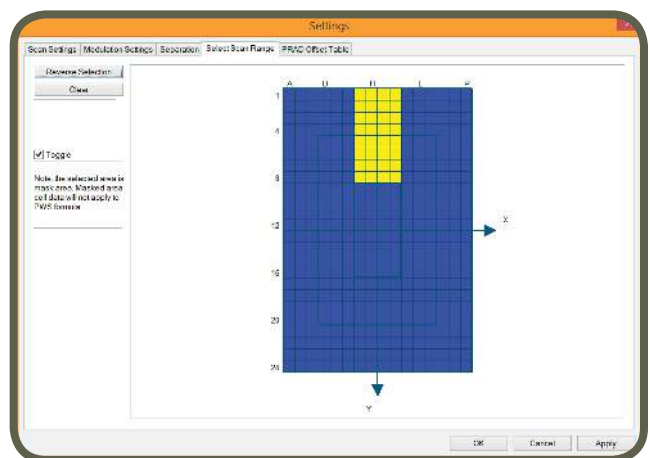
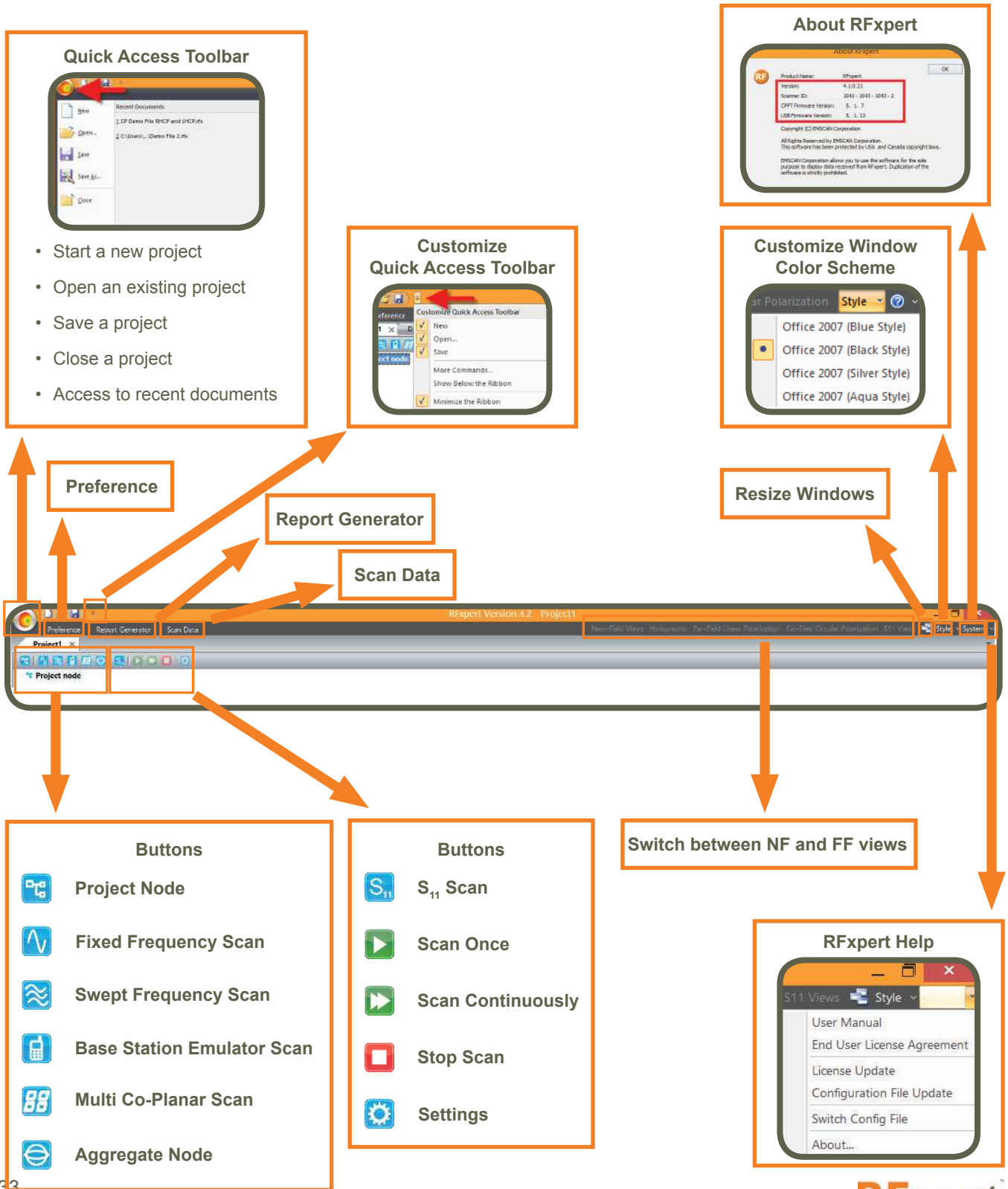

Fig. 10. Removing the effect of the cable

Menu Bar

The Menu Bar with a minimized Ribbon is shown below. This bar allows the user to choose a project node, to select a scan type, to start a single scan, to scan continuously, and to stop a scan, as well as to specify scan settings.



RFExpert Software Menu Bar

The Menu Bars with a maximized Ribbon are shown below.

The Preference tab displays the options for scan data. Please go to [page 45](#) for details.

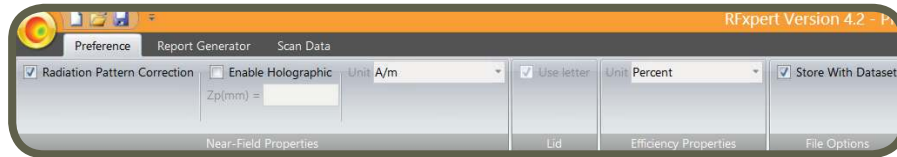

The Report Generator tab displays the options to be imported to a report. Please go to [page 48](#) for details.



The Scan Data tab displays the options in the Scan Settings tab of any scan type.

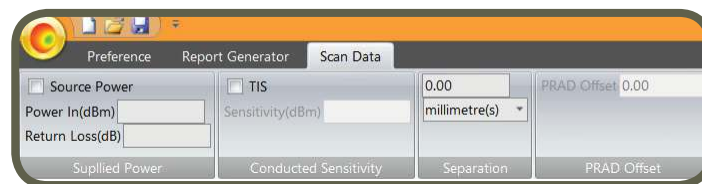

Quick Facts about Status Bar

Status Bar is positioned at the bottom of the client software. Status Bar is shown below. This bar displays number of scans, progress bar, external equipment connected and the RFxpert connection button.

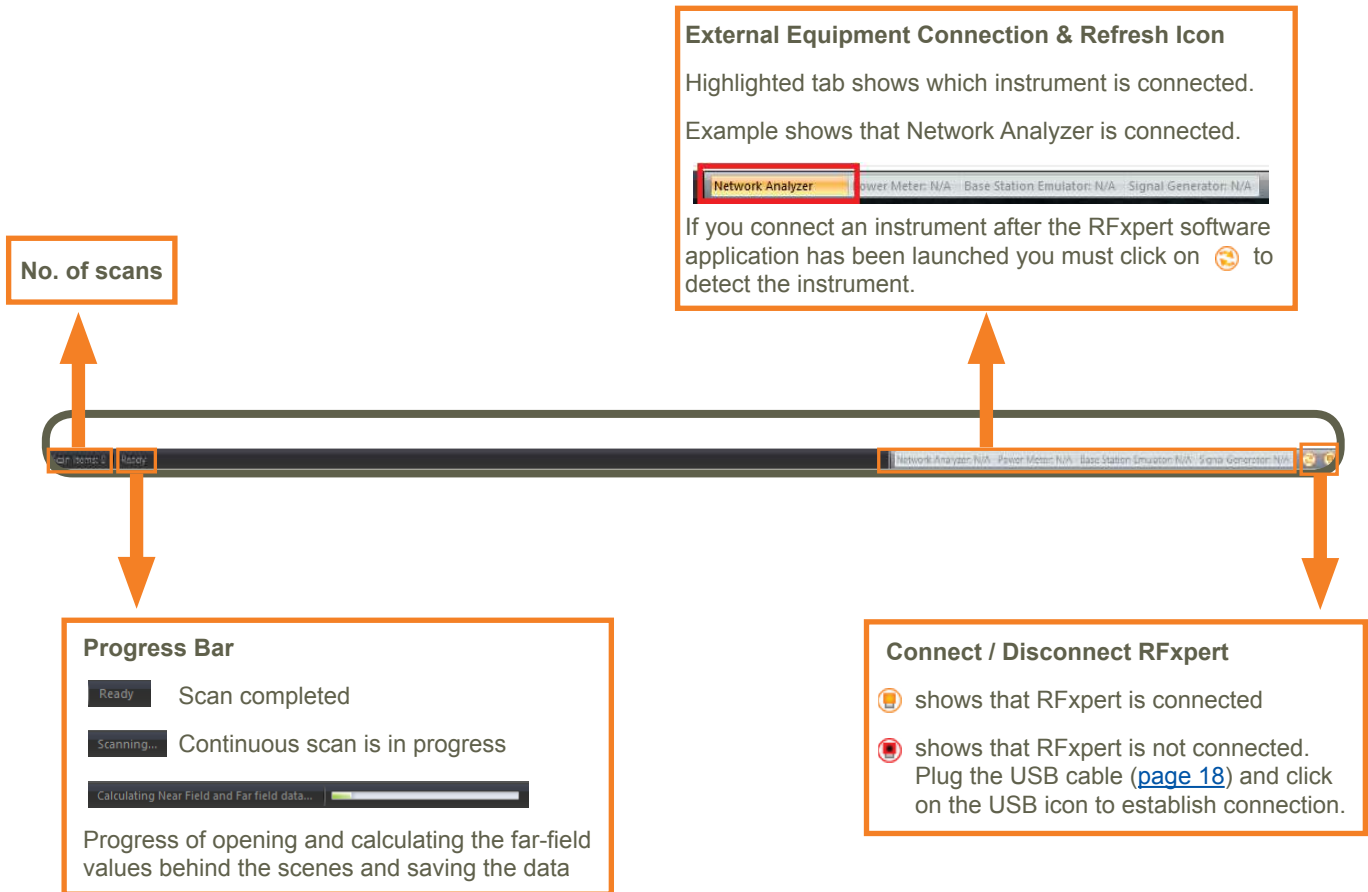

Quick Facts about Menu Bar

Multiple project files can be opened at the same time. Each file will have a tab showing the project name. If there is no room to show the name of all opened projects the names can be accessed from the drop down menu.

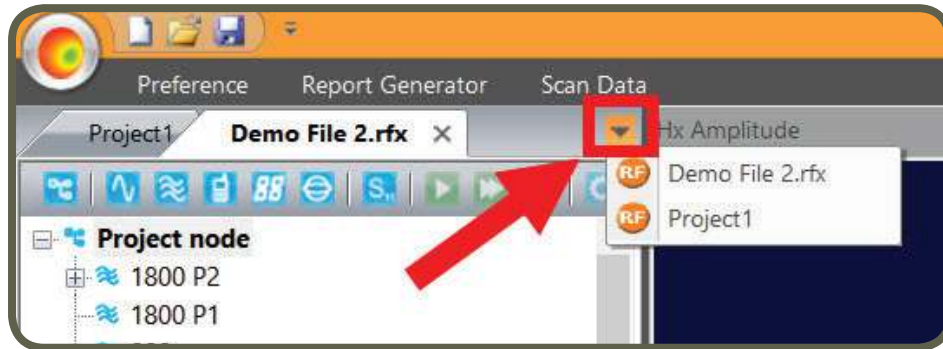

If there are any changes compared to the saved version of the project file this will be indicated by an asterisk behind the file name. Ensure to save the file before closing.

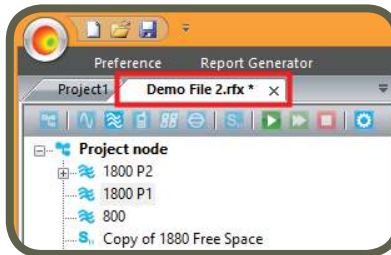

The ribbon bar can be displayed/maximized or hidden/minimized. To switch between the minimized and maximized state, right click anywhere on the dark grey ribbon e.g. Preference and click on “Minimize the Ribbon”. And to maximize click on “Minimize the Ribbon” that should have a check mark next to it. The ribbon bar has preference, a report generator and scan data functions. Details on these functions can be found on [page 45](#), and [page 48](#).

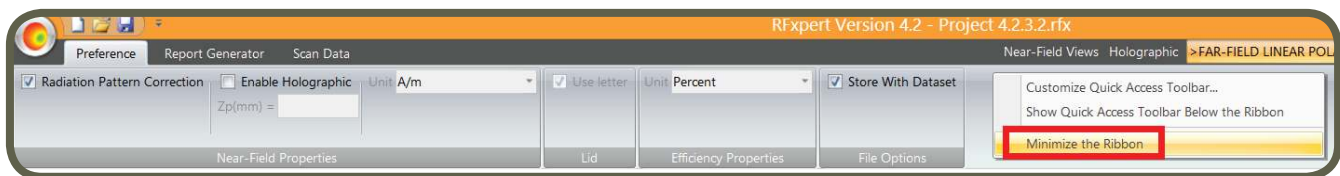

Nodes

All project trees, scan types and notes are called nodes. A project tree can be considered as a repository to store related data. You can add project node, different types of scans and/or notes to a project node. You can rename, copy and paste a node or node settings only.

How to Add a Scan Type and Select Scan Settings?

To add a scan type either right click on the Project node and then select one of the scans, or click on one of the icons on the task bar above the Project node.



To select scan settings, either click on  in the main control bar or right click on the scan node and then left click on "Node Settings".



How to Rename a Node?

You can rename any node type. To rename a node or to further specify or label any scan types, left click on the gray colored named field e.g. "Project node". Then click on it again and enter the new name for the field.



How to Copy and Paste a Node or a Node Setting?

To create scans with similar settings, you can copy a scan node or create a new node (of that type) and copy settings. To copy a scan node first right click on the node and select “Copy Node”. Then right click on “Project node” and select “Paste Node”.

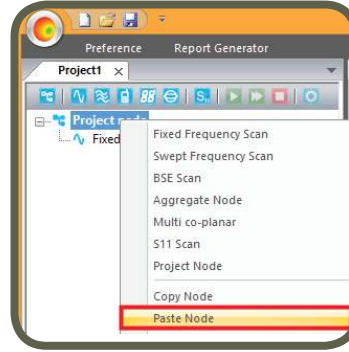
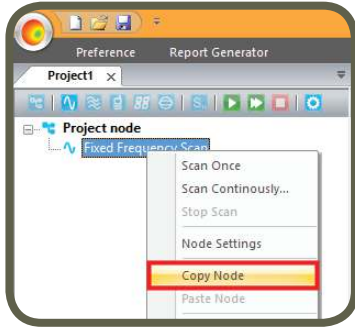

To copy the settings of an existing scan node to a new scan node, first select the scan type then right click on the node that you want to copy and select “Copy Node”. Then right click on “Project node” and select “Add Node With Copied Settings”.

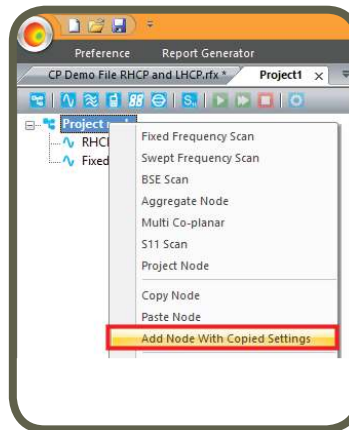
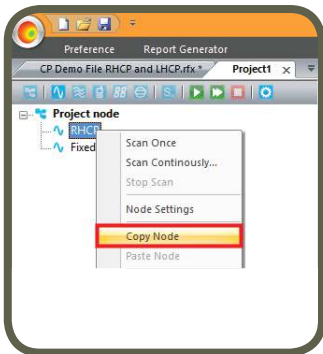

A Project Node in one file can be copied to a different file. To copy a Project Node first right click on the Project Node and select “Copy Node”. Then switch to the other file and right click on “Project node” and select “Paste Node”. A Project Node can not be copied in the same file.

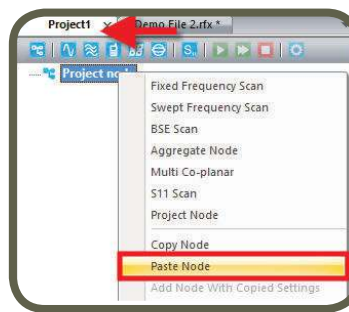
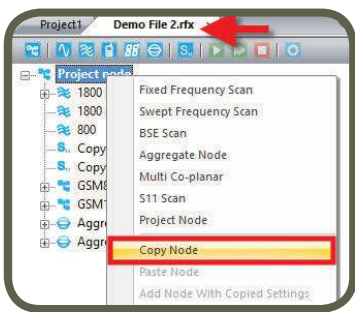

How to Export Data to Excel or Copy an Image?

To export data to Microsoft Excel, right click on the node, and select “Export to Excel”. The window below will appear (Microsoft Excel must be installed on your computer).

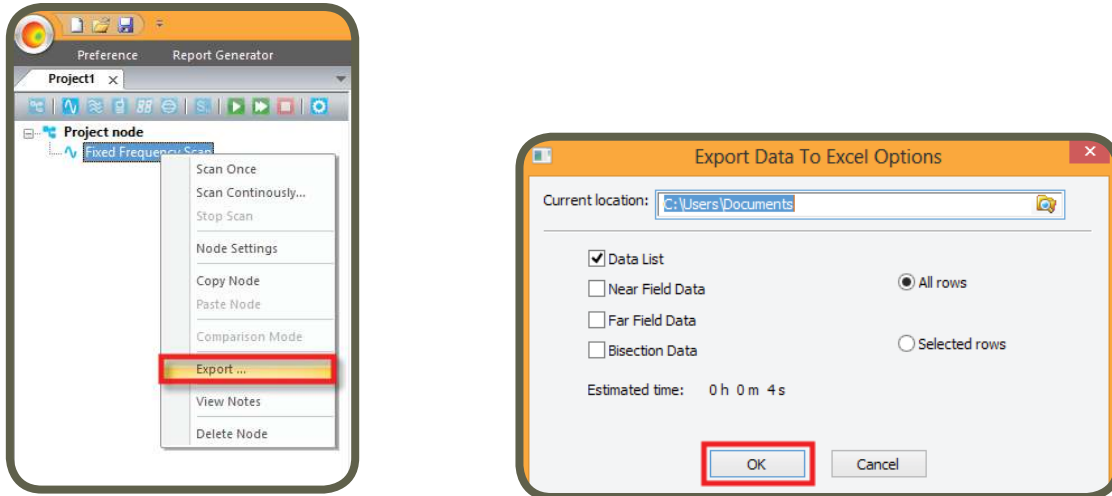

You can choose specific data or all data (Data List) to export to Microsoft Excel.

To copy an image, right click on the image and select “Copy Image” (below image on the left). To export data to an excel file, right click on the image and select “Export to an Excel file” (below image in the middle).

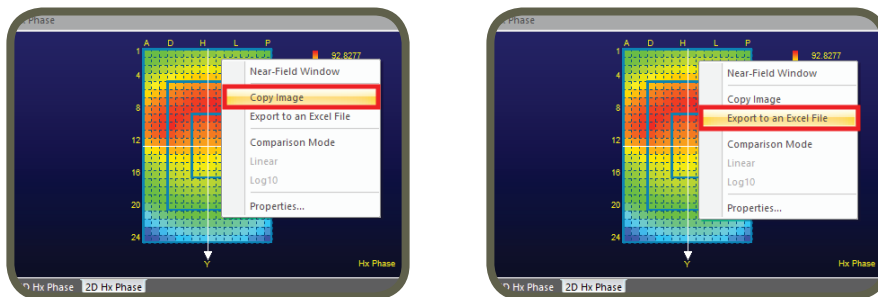

How to Add Note to a Node?

To add notes to project node or any other scan types, right click on the node and select “View notes”.

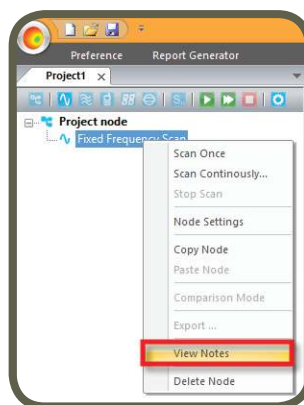

Viewing Scan Results

You can view the scan results of “Fixed Frequency Scans” and “Swept Frequency Scans” in three modes: Near-Field View, Far-Field View Linear Polarization and, license permitting, Far-Field Circular Polarization. Please refer to [page 55](#) for viewing “S₁₁ Scan” results. You can switch views from the view tool bar that is on top right corner.

Near-Field Views

Near-Field View displays renderings of near-field amplitude and phase patterns. These results are further broken up in the two polarizations Hx and Hy. The results are from the scanner surface located 25 mm below the scanner lid surface.



There are 8 windows for the Near-Field View: Each of the polarizations can have Amplitude and Phase shown in 3D or 2D views. You can switch between the 3D and 2D views by clicking on the tabs at the bottom of any window.

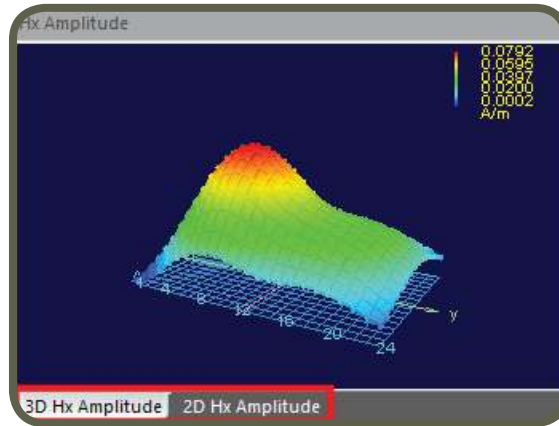

In all 2D image windows, when the cursor is moved to any cell, column, row and variable value (e.g., magnitude or phase of Hx or Hy) is displayed. In all 3D image windows, you can rotate the image, by left clicking on the image and dragging it. To return the image to its original position, right click on the image and select “Reset position”.

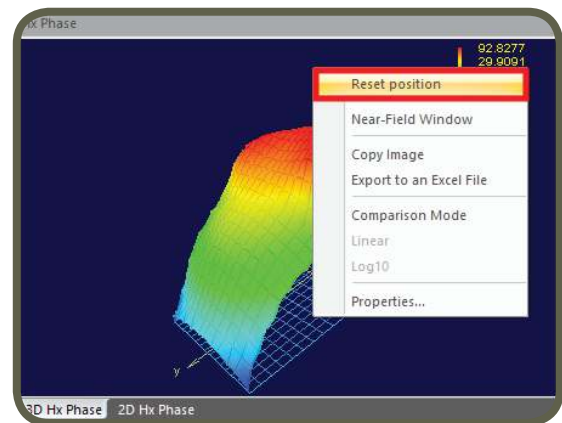
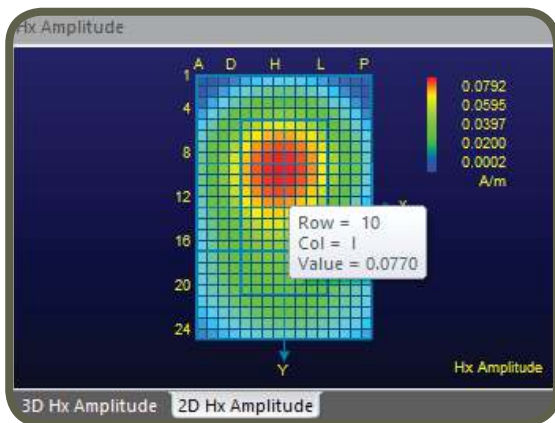

RFxpert Software
Viewing Scan Results

To expand the window double (left) click within the red outlined parts of the window (below image on the right). To return to the original size double click on the same area again.

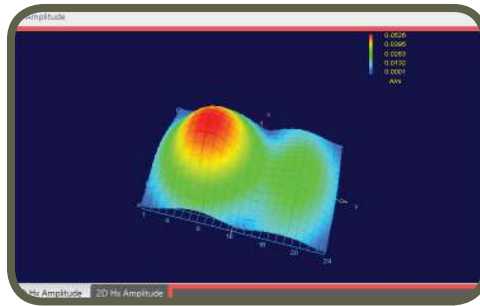

Far-Field Views

Right click on the far-field image to display menu options (Image on the right). You can reset the position; define cuts to be displayed; copy the image, export data of the image to Excel; display Normalized to 0 dB, directivity, gain, realized gain, phase or properties of the image.

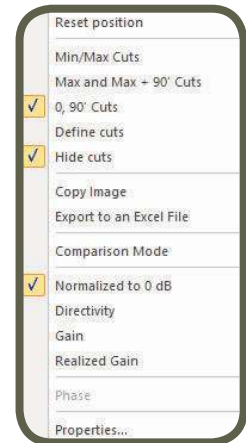

Far-Field Views Linear Polarization

In the Far-Field Linear Polarization View there are 8 views: three hemispherical views (Combined, Theta, and Phi), three Bisection views (Combined, Theta, and Phi), and two Bisection Cut views containing the Combined, Theta and Phi patterns.



From any one of the three renderings of the hemispheres you can define which phi angles the bisection cuts represent by right clicking on the image. In the default state, these cut lines are hidden. They can be displayed by un-checking the Hide Cuts option. To customize cut angles left click on “Define Cuts”. A dialogue box will pop up as shown in the image below. You can either enter the angle or slide the button for desired selection.

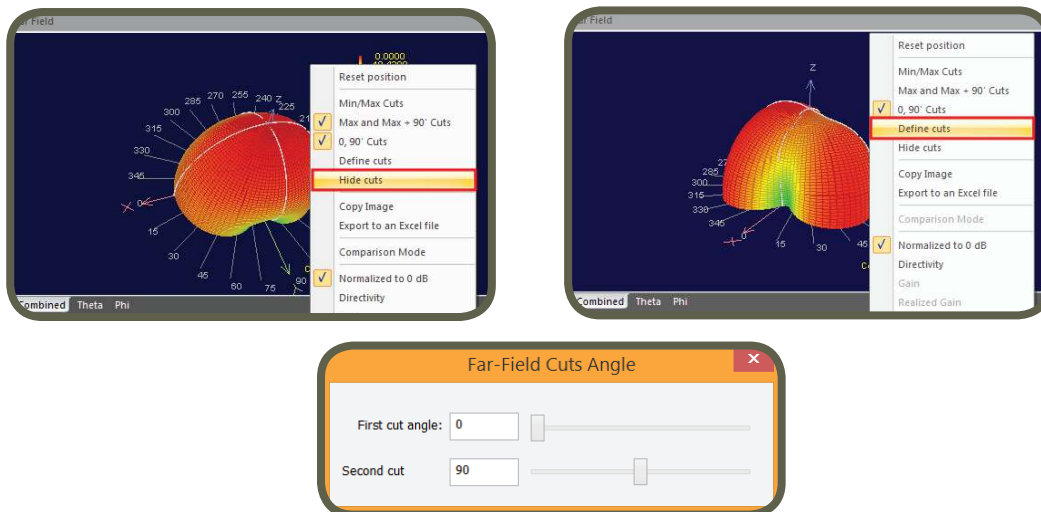

As described in the Near-Field Views section you can also “Copy Image”, “Export to an Excel file”, or rotate the image and reset to the default position.

RFxpert Software
Viewing Scan Results

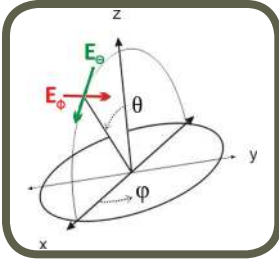

The cuts that determine the views in the bisection window can be displayed as white cut lines on the 3D far-field pattern. There are several options for selecting which cuts will be displayed. The first one is Min/Max, which will display the cuts that contain the minimum and maximum values of the far-field pattern. The second is Max and Max +90° Cuts. This will search out the maximum value and display this cut along with the orthogonal cut. The last one is 0, 90° Cuts which will display the 0 and 90° values of the far-field pattern.

In all bisection view windows, you can switch between Cartesian and Polar view by right clicking in the window area. You can select the data to be displayed in the Bisection Cut1 and Cut2 windows by right clicking on the display area and then checking Combined or Theta or Phi.

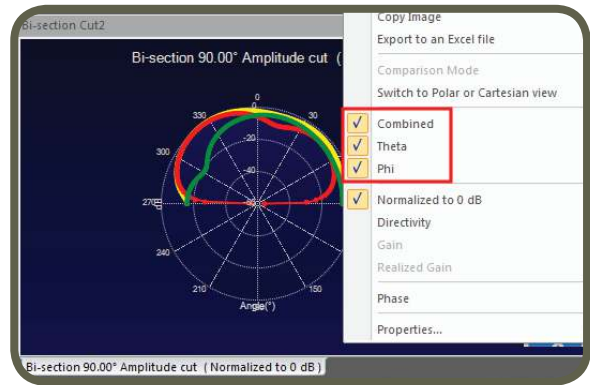
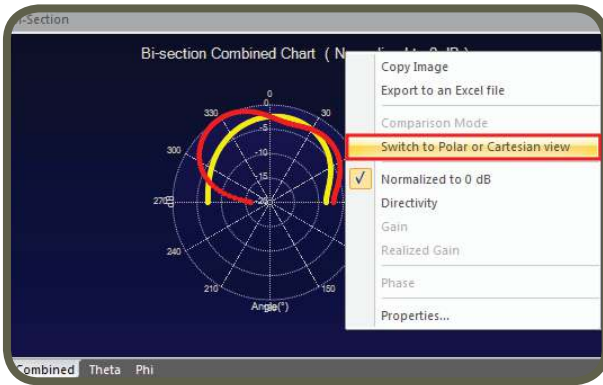

Far-Field Views Circular Polarization

The circular polarization is an optional and licensed feature that can be enabled on any system. The part number for this option is 3000-0303. Please contact [EMSCAN](#) or your dedicated EMSCAN Sales Associate to place an order. There are 10 windows in this view: Four hemispherical views (Combined, RHCP, LHCP, and Axial Ratio), four Bisection views (Combined, RHCP, LHCP, and Axial Ratio), and two Bisection Cut views containing the Combined, RHCP and LHCP patterns. Similar to the linear polarization views you can switch between Polar and Cartesian views and you can select the data to be displayed in the bisection Cut1 and Cut2 windows by right clicking on the display area and then checking Combined or Theta or Phi.

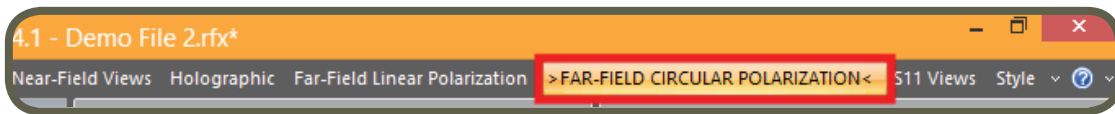

Data List / Charts Window

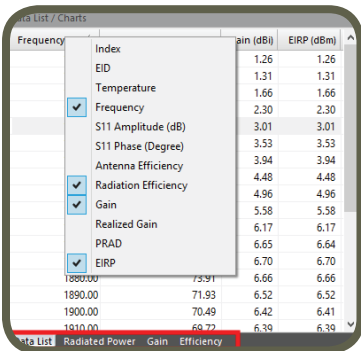

“Data List” table can be used as a data navigation tool, when either many single scans are run or continuous scans are run. You can also switch between the Radiated Power “Data List” and Radiated Power “Chart” using the tabs at the bottom of the window. The Radiated Power “Data List” displays power “measurements” in the far-field, EIRP – effective isotropic radiated power or PRAD – total radiated power (measured for one hemisphere).

The Radiated Power “Data List” shows EIRP and PRAD values for single or multiple samples. Other contents of the “Data List” can be selected by right clicking on the Frequency, Efficiency, Gain, PRAD, EIRP title row.

Column selection menu will appear. Check the items to be displayed on the “Data List” from the menu.

RFxpert Software Viewing Scan Results

The far-field 3D views are presented in a Directivity sense by default. You can switch between different representations of the far-field by right clicking on a far-field window or chart. The options are to have the far-field displayed in terms of normalized to 0 dB, Directivity, Gain, or Realized Gain.

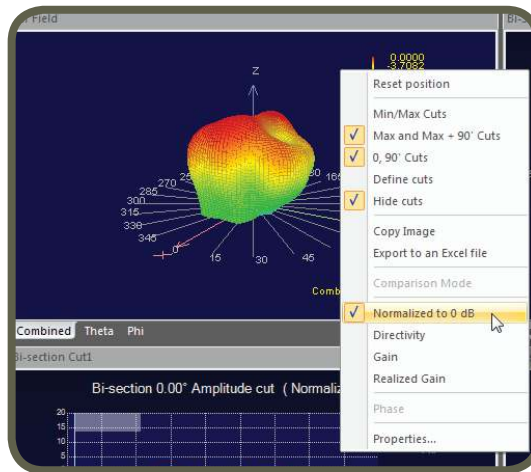

Modifying “Data list” Content

“Data list” can be further processed or modified by right clicking on any entry in the row in the table, and then clicking on the choices presented. You can retrieve the data that is unintentionally deleted by right clicking on the “Data list” and then clicking Un-Delete.

Note: If you save a file after deleting a data, the deleted data cannot be restored.

Swept Frequency data can NOT be deleted/un-deleted

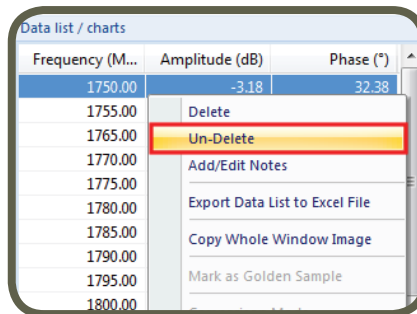

To add/edit notes for a particular measurement row click on “Add/Edit Notes”. Enter the title, and the details of the note. To view the note, move the cursor to the specific row, and right click to choose “Add/Edit notes”.

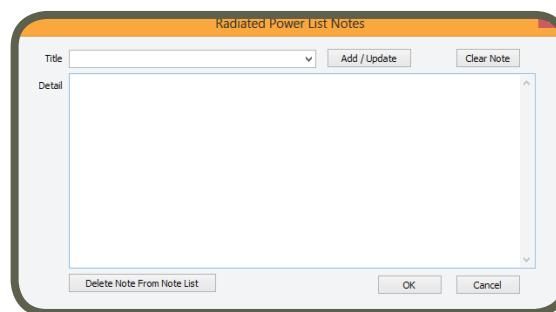
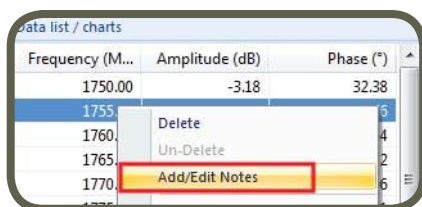

RFExpert Software Viewing Scan Results

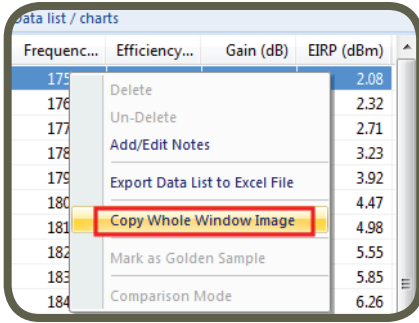

Clicking on any data row will update the rest of the views to reflect the patterns generated for that particular sample measurement. To copy all the views associated with a particular row in the “Data list” click on “Copy Whole Window Image”. To export data to an Excel file, right click on the image and select “Export to an Excel file”. To copy one image, right click on the image and select “Copy Image”.

The Radiated Power chart shows a plot of the PRAD and EIRP values over a sequence of samples. To export data (the whole table) from Radiated Power “Data list”, right click on the table, and select “Export to an Excel file”.

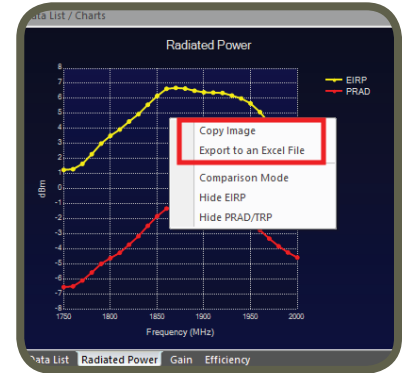

To copy an image right click on the image and selecting “Copy Image”. You can paste the image on any of your reports.

In all 3D image windows, you can rotate the image, by left clicking on the image and dragging it. To return the image to its original position, right click on the image and select “Reset position”. When the cursor is moved to any cell on 2D images; column, row and relative phase angle data information is displayed. In all 2D charts, you can zoom in by clicking and dragging over the area to zoom to. While zoomed in you can scroll through the chart using the scroll buttons on top and to the side of the chart. To reset the zoom, simply double-click on the chart.

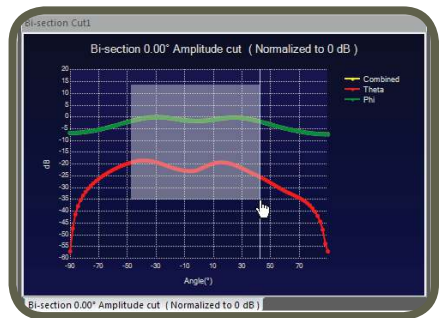
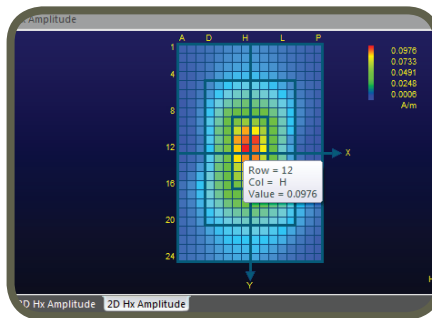
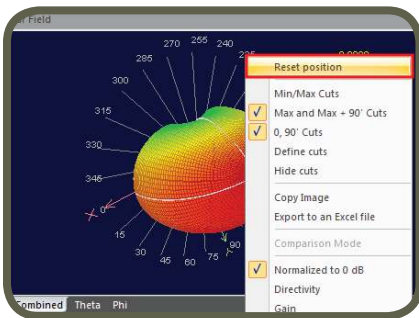

The default setting for the amplitude scales for the Near-Field Pattern is auto scale. To set the scale controls manually, right click on any image, and select “Properties”.

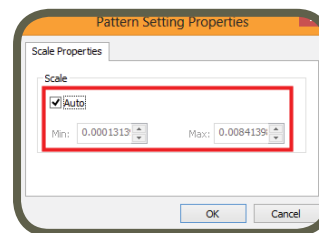
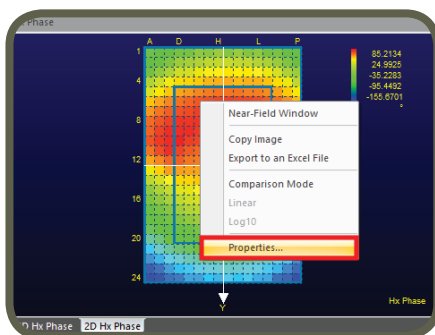

Preference

The Preference option has settings for the user's preferred units. When the user has a scan that contains near-field data they will have the option of switching between units of dB μ A/m and A/m for the near-field data.

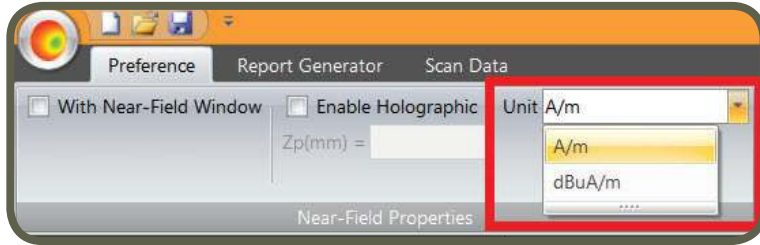

When there is a scan that contains efficiency data there will be the option of switching between units of dB and % for the efficiency value.

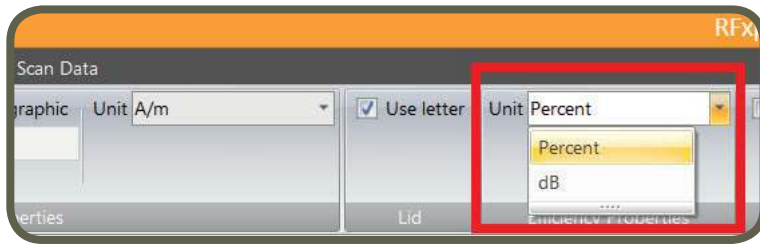

If the user has an RFExpert which comes with columns indicated by numbers rather than letters, they can change the software to also display columns as letters.

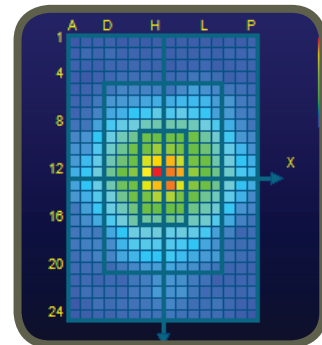
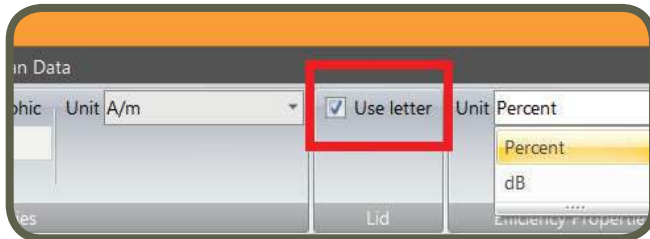

Client SW calculates far-field data based on near-field data in the background. If a project file is saved without checking Store with Dataset, client SW will not store the calculated far-field data and will calculate the far-field every time this file is opened.

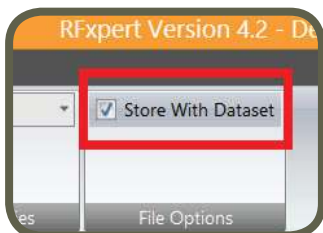

Note:
Saving a file with Store with Dataset checked enables immediate analysis of the scanned data; however, file size can be 300-400 times bigger. Otherwise every time you open the file, the near-field data is processed to provide the far-field results and it may take time for a large dataset.

Radiation Pattern Correction

The Radiation Pattern Correction is designed to improve the pattern accuracy, especially at high frequencies. It is visible when the ribbon is not minimized.

It combines the Near-Field Window and the Far-Field-Correction Window. The role of the near-field window is to minimize the effect of truncation error that occurs due to the finite size of the scanner. The far-field correction window is correcting for the finite aperture effect.

This feature is ON by default for scans at any frequency. It should be unchecked for a Multi Co-Planar scan (MCP).

Though it is not recommended, the Radiation Pattern Correction function can be turned off by simply deselecting the check box. It will allow comparison with older scans that were run without the Near-Field Window and Far-Field Correction Window.



The Near-Field Window corrects for the ripples created by the Fourier transformation of a data set ending abruptly.

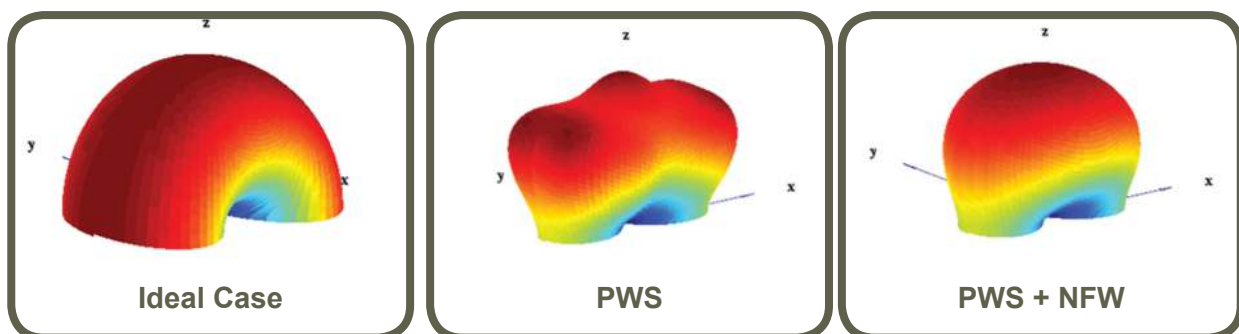
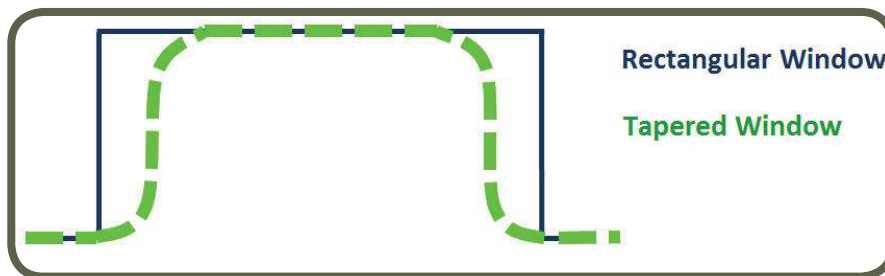

RFxpert Software
Viewing Scan Results

The Far-Field Correction Window deals with the pattern compression due to the finite aperture. A compressed pattern would result in over estimated gain and a wasp shape pattern at 90 degrees.

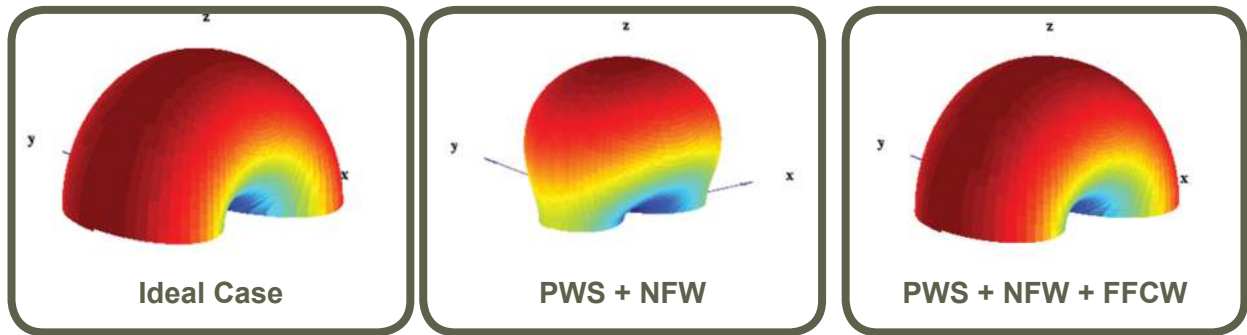

This The Radiation Pattern Correction is optimized for antenna elements in the center of the scanner. If the elements cannot be placed in the center of the scanner it may be better to process the data without the Near-Field Window. Significant near-fields within 5 cm of the center for the RFX2 and within 2 cm of the center for the RFX would be considered in the center.



Holographic Projection

Also known as back projection this feature will calculate the magnetic fields on a planar surface at any distance from the scan plane. The default distance is set to 0 mm which corresponds to the surface of the scanner’s lid.

To select a distance other than the surface of the lid, simply enter the distance in mm. Positive numbers show the projected fields below the lid; negative numbers above the lid which should be used if the antenna is away from the lid.

Note: Currently the holographic projection will derive the fields on an infinite ground plane and display them on an aperture equal to the scanner size. This means it will not currently be useful to estimate currents on a specific metal structure such as an antenna array.

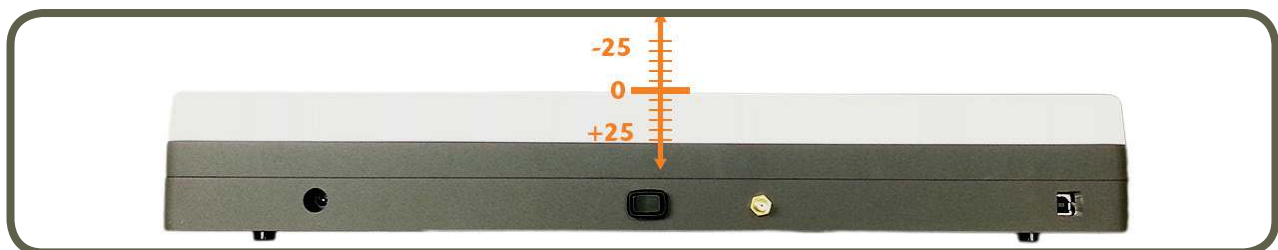

Report Generator

The report generator will export a set of images from the RFExpert project directly into a Microsoft Word document. It requires that Microsoft Word 2007 or later version be installed on the computer. To use the report generator, select the scan from which you want the results. Only results from one scan can be exported at one time.

Go to the Report Generator section and choose the type of scan results you want. There are two selections, 3D plots and the 2D plots. To switch between these views choose the drop down menu at the far left.

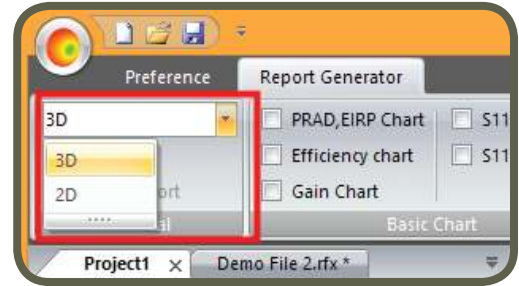

Each results window available in the RFExpert software is also available for the report generator. There are a total of 37 different results available. Some scan types will not have all 37 available if they are missing some of the required data for a scan type. Those will be grayed out in the report generator tab.

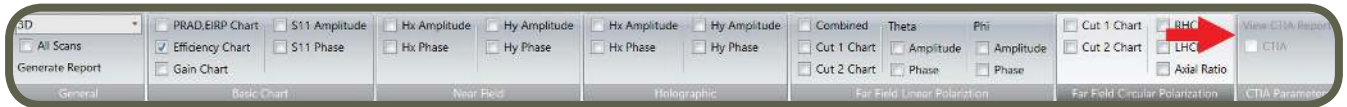

The exported results must come from a single scan node in a single project file but multiple results can be exported into the report. If “All Scans” is not selected then only results from the selected measurement table will be exported. If “All Scans” is selected then every measurement result in the scan node will be exported. Note that if there are a lot of scan results, this can take a long time (depending on the processor speed of the computer, up to 30 seconds per measurement).

There is a separate report section called CTIA Parameters. It will create a report with all the CTIA measurement data required for a mobile phone. This report is only available for a Fixed Frequency Aggregate Scan. This section will thus remain greyed out unless you click on an Aggregate Node built from two Fixed Frequency scans. For the list of all the CTIA parameters, please go to [page 103](#).

After checking the boxes, click Generate Report.

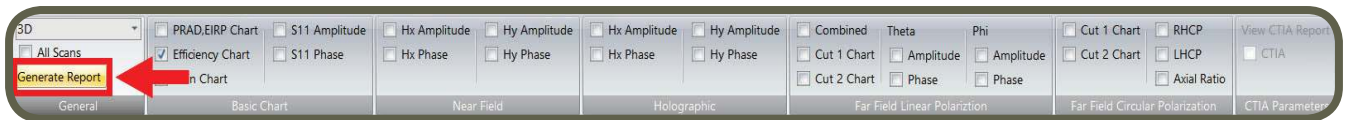

Microsoft Word will be opened and you will be asked to save the document. Switch to Microsoft Word and click to save the document. If you click Don't Save, Microsoft Word will be closed without saving the document.

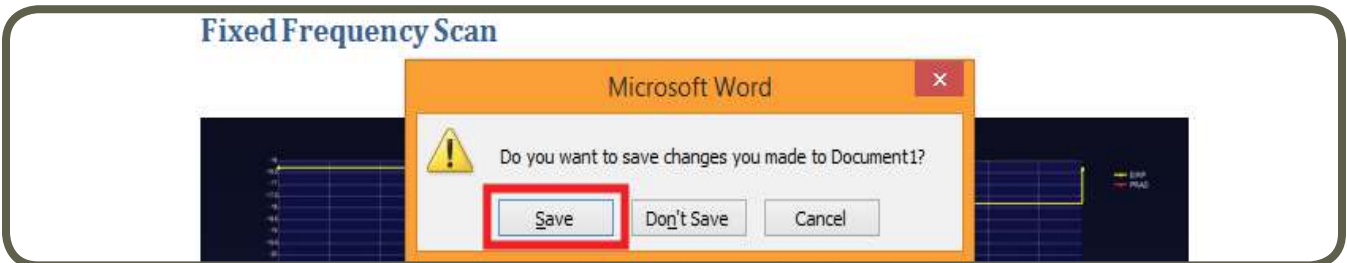

Scan Types

There are five scan types:

- **Fixed Frequency Scan:** Power, sensitivity and pattern measurement of a device under test at a discrete frequency. With manual entry of source power and return loss, the software will also calculate gain and efficiency; if conducted sensitivity value is entered, TIS will be predicted.
- **Swept Frequency Scan:** S_{11} , power, pattern, gain, and efficiency measurements at a single frequency or a series of frequencies over a span through the remote control of a [Network Analyzer \(https://www.emscan.com/products/antenna-testing/rfx2/\)](https://www.emscan.com/products/antenna-testing/rfx2/). Scripts can be written.
- **S_{11} Scan:** S_{11} parameter measurements as a function of frequency. S_{11} amplitude and phase are measured at a single frequency or a series of frequencies over a span through the remote control of a [Network Analyzer \(https://www.emscan.com/products/antenna-testing/rfx2/\)](https://www.emscan.com/products/antenna-testing/rfx2/). Scripts can be written.
- **Base Station Emulator Scan:** Power and pattern measurements at a single frequency or a series of frequencies over a span through the remote control of a [Base Station Emulator \(https://www.emscan.com/products/antenna-testing/rfx2/\)](https://www.emscan.com/products/antenna-testing/rfx2/). Scripts can be written.
- **Multi Co-planar Scan (only for RFX2 model):** Power and pattern measurements at a single frequency for larger antennas like a 2.32 m x 2.32 m phase array antenna or a 2.32 m long antenna. RFxpert combines up to 36 very-near-field measurements to provide far-field results in seconds. The 36 measurements are defined by up to 6 columns and up to 6 rows. This scan type can be applied to Fixed Frequency or Swept Frequency or Base Station Emulator Scan types.

Fixed Frequency Scan

To run a “Fixed Frequency Scan”, right click on Project node, and choose “Fixed Frequency Scan” or just click the “Fixed Frequency Scan” icon  on the task bar.

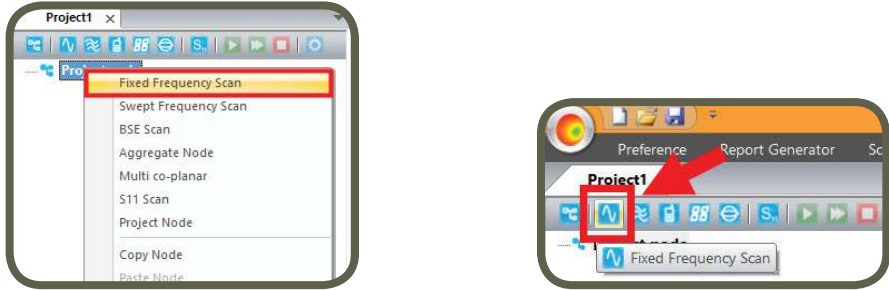

To set the frequency, click on  in the main control bar or right click on “Fixed Frequency Scan” and then left click on “Node Settings” and “Scan Settings”.



Scan Settings Tab

Set the frequency of the scan.

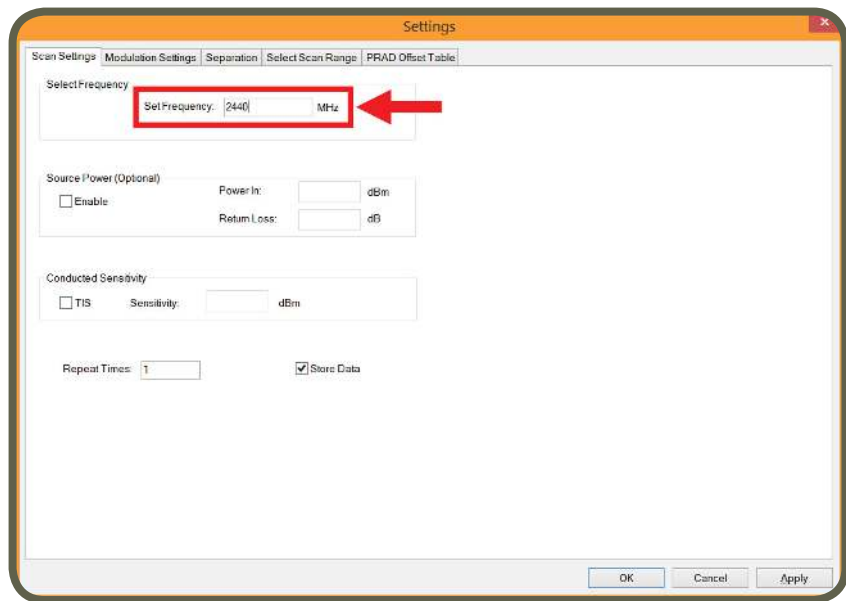

RFxpert Software Fixed Frequency Scan

If you know the Power In and Return Loss values of the DUT, RFxpert will calculate the gain and efficiency without using a Network Analyzer. Simply, check Enable box under Source Power (Optional) and enter Power In and Return Loss values. Note that this option can only be set when you first create a Fixed Frequency Scan. If you run the scan without enabling this option then gain and efficiency values will not be calculated.

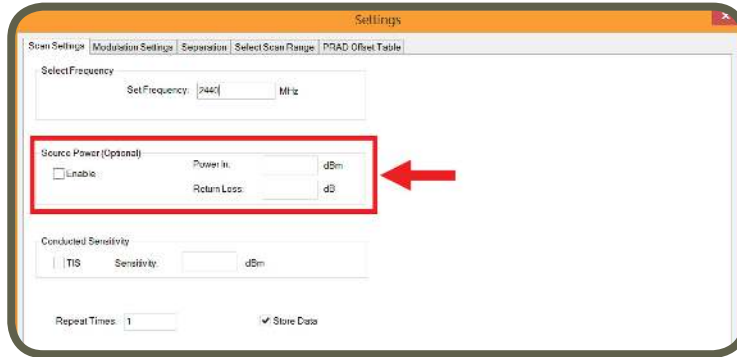

If you know the Conducted Sensitivity value of the DUT, RFxpert will estimate the TIS of the DUT without going through a time consuming test plan. You must first enable and complete the Source Power data fields.

Please go to [page 82](#) in the FAQ section for an explanation of the RFxpert TIS proxy.

You also have the option to select the number of scans to run. Repeat Times is 1 by default. You can enter any value between 1 and 34464. Clicking on the Single Scan button will now do multiple scans up to the Repeat Times entered. The Store Data selection will either append the new scan data to the data list or simply replace the last scan data e.g. check Store Data box, and enter 3 for Repeat Times. RFxpert will scan three times and display all three scan data. Now uncheck the Store Data box and enter 3 for Repeat Times. RFxpert will scan three times and display the last scan data only.

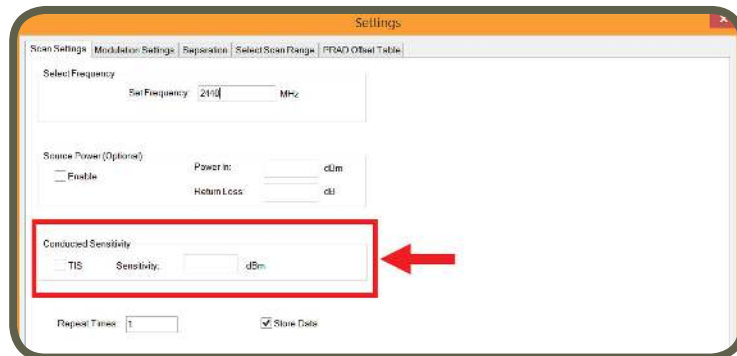

Modulation Settings Tab

You can adjust the modulation settings by selecting between a constantly on power source (CW/CDMA), a bursty source (labeled here as Bursty/TDMA/etc) or Advanced Setting for intermittent but predictable signal sources (e.g. WiFi) in the Modulation Settings window (minimum pulse duration that RFxpert can support is 500 us). The Bursty/TDMA setting is tuned to measure GSM mobile devices but it may also support some WiFi and other bursty signals. If a signal is not supported, the Advanced Settings can usually be modified to measure almost any signal type.

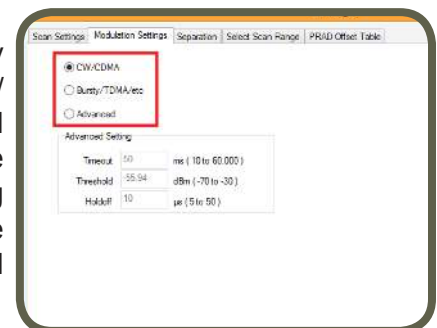

Note:

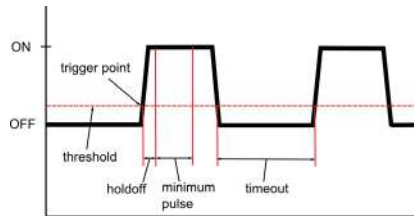

The advanced settings is used to synchronize the data capture with unusual pulse settings. A timeout period should be chosen first. This will ensure the system does not get stuck waiting for the next pulse indefinitely. The initial period should be chosen so that it is about 5 times the actual duration between bursts. Using an antenna and a oscilloscope can help to determine this timeout period.

The threshold should be chosen so that the transition from ON to OFF will cross the threshold level. If the threshold value is not known, it can be determined by trial and error; as a starting point, use -53 dBm and go up by 1dB increments until the signal is capture or the upper limit is reached. If this does not capture a signal then go down by 1dB increments.

Once the hardware detects that the transmitted power has crossed the threshold level the system will wait for a holdoff period before beginning data capture. This holdoff period can typically be left at the default value unless the burst has a very slow rising envelope. After data capture has begun a minimum pulse duration of 500us is needed to ensure accurate measurement. Finally a timeout period can be specified.

Separation Tab

The near-field to far-field transformation needs to know the distance between the scan plane and the antenna plane. The default value is assumed to be 25 mm which means that the antenna must be positioned directly on the surface of the scanner.

For many devices it will be impossible to position the antenna so it is exactly on the scanner surface. To account for these types of devices there is an increased separation value that can be set. In the settings window of Fixed Frequency Scan, Swept Frequency Scan and BSE Scan there is 'Separation' tab.

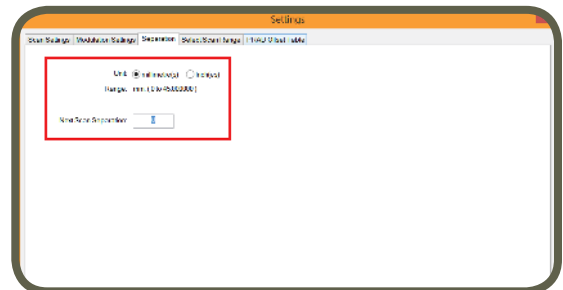

Simply enter the distance between the antenna and the surface of the scanner in millimeters or inches. The maximum separation value that you can enter for RFX is 45 mm and for RFX2 is 115 mm. The displayed limit will change automatically based on the connected hardware i.e. RFX or RFX2. The far-field calculation will be automatically adjusted to account for the increased distance.

Note that the measured values will vary as the separation changes even when inputting the proper separation parameter but they will maintain the overall system accuracy.

Select Scan Range (Near-Field Mask) Tab

Please refer to [page 62](#).

PRAD Offset Table Tab

Please refer to [page 64](#).

Swept Frequency Scan

This is the most comprehensive scan option which can measure power, pattern, gain, and efficiency. Scripts can be written to test a range of frequencies through remote control of a Network Analyzer. To set scan settings, first right click on the scan node and then left click on “Node Settings” to get the following screen.



Frequency Settings Tab

- To specify a sequence of equally spaced settings, set the start and stop frequencies along with the number of samples (i.e. the spacing between points).
- Then click “Add” button under “Linear Sweep”. These will be populated in the right-hand window.
- To add discrete frequencies enter a value in the window under “Single Point” and click “Add” button in “Single Point” to enter. “Single Point” entry method can be repeated number of times (maximum number of total entries is limited by the number of VNA settings).

Network Analyzer Tab

To set the GPIB address for the network analyzer, click on Network Analyzer Settings. Most [Network Analyzers \(https://www.emscan.com/products/antenna-testing/rfx2/\)](https://www.emscan.com/products/antenna-testing/rfx2/) are automatically identified by RFxpert software once they have been detected by the Keysight IO Libraries Suite. If this is the case you can leave the GPIB address as 0. You don't have to set up any GPIB address when the network analyzer is connected to the PC using crossover Ethernet (IPv4) or USB.

If the Network Analyzer was connected after the RFxpert application was opened, the RFxpert Application needs to be made aware of this new instrument. On the orange RF icon on the START Menu, left click and select Refresh Instrument or click on the  at the bottom right of the RFxpert application until you see Network Analyzer highlighted.

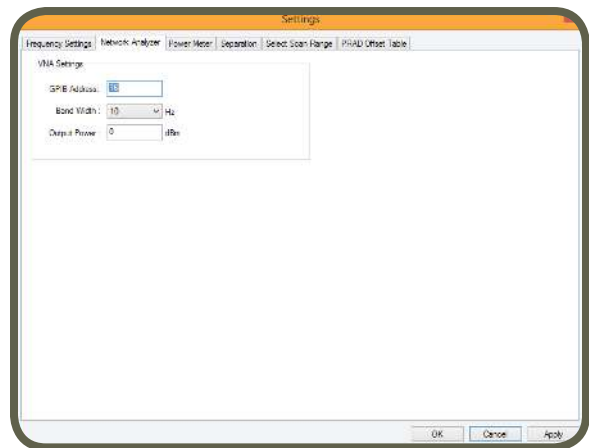

Power Meter Tab

When using a Network Analyzer as the power source to the DUT it is important to calibrate the output power of the instrument. To do this, Please refer to [the “creating a profile” section under “Connecting Power Meter and Network Analyzer”](#)

RFxpert Software Swept Frequency Scan

The “Data list” is now showing the following important columns: index, frequency steps, S_{11} , gain, efficiency, PRAD and EIRP. By right clicking on the Data list / charts header for a drop down menu, the columns can be hidden or displayed at the user’s discretion (shown on the right).

In addition to the “Data list”, charts of Radiated Power, Gain and Efficiency can also be displayed by clicking on the bottom task bar.

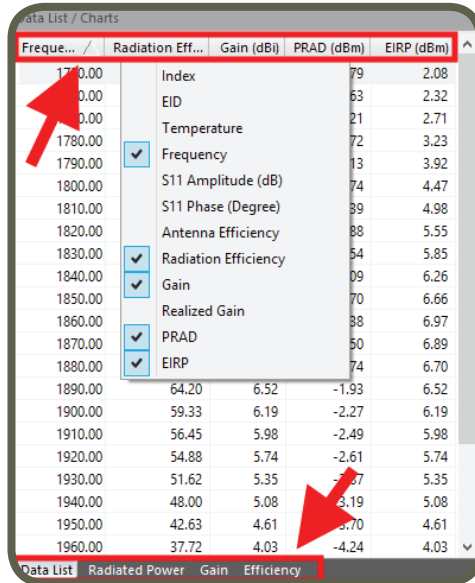

Select Scan Range (Near-Field Mask) Tab

Please refer to [page 62](#).

PRAD Offset Table Tab

Please refer to [page 64](#).

S₁₁ Scan

The network analyzer measures the S₁₁ parameter of the DUT and RFxpert simply stores and displays the measured data. To set scan settings, first right click on the scan node and then left click on “Node Settings” to get the following screen.

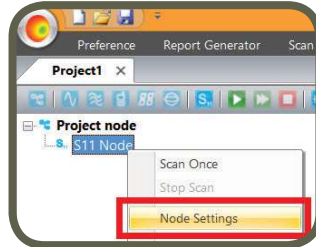

Frequency Settings Tab

- To specify a sequence of equally spaced settings, set start and stop frequencies along with the number of samples (i.e. the spacing between points).
- Then click “Add”. These will be populated in the right hand window on Frequency Settings tab.
- To add discrete frequencies enter a value in the 4th window (Single Point) and click “Add” button in “Single Point” to enter. “Single Point” entry method can be repeated number of times (maximum number of total entries is limited by the number of VNA settings).

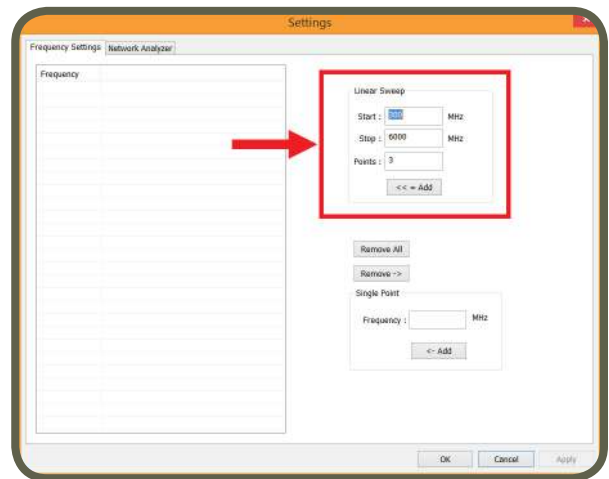

Network Analyzer Tab

To set the GPIB address for the network analyzer, click on Network Analyzer Settings. Most [Network Analyzers \(https://www.emscan.com/products/antenna-testing/rfx2/\)](https://www.emscan.com/products/antenna-testing/rfx2/) are automatically identified by RFxpert software once they have been detected with the Agilent IO library. If this is the case you can leave the GPIB address as 0.

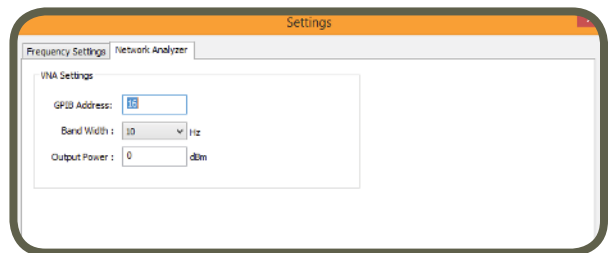

Typical scan result is shown below.

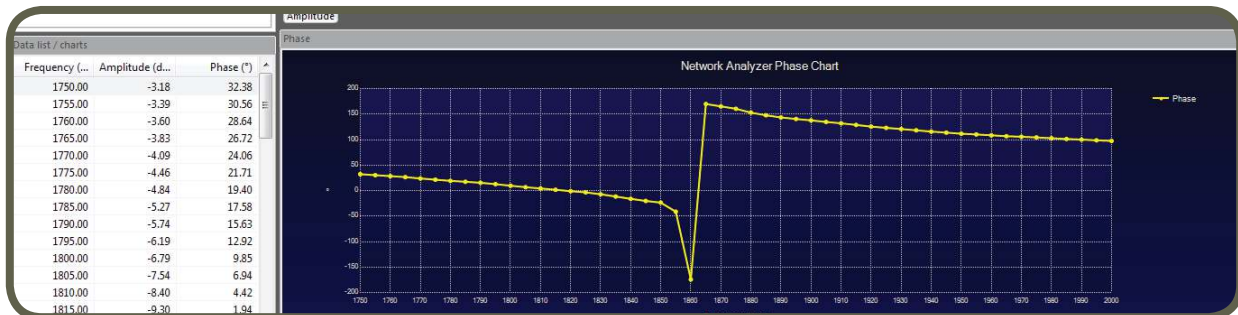

Base Station Emulator Scan

Base Station Emulator Scan is an optional and licensed feature that can be enabled on any system. The part number for this option is 3000-0300. Please contact [EMSCAN](#) or your dedicated EMSCAN Sales Associate to place an order.

This scan option enables power and pattern measurements at a single frequency or a series of frequencies through the remote control of a base station emulator.

This scan is similar to the Swept Frequency Scan. The only difference is that instead of a network analyzer, a base station emulator is used. To connect to the instrument, first use the Keysight IO Libraries Suite interface to add the instrument. If the BSE was connected after the RFXpert application was opened, the RFXpert Application needs to be made aware of this new instrument. On the orange RF icon on the START Menu, left click and select Refresh Instrument or click on the “icon” at the bottom right of the RFXpert application until you see Base Station Emulator highlighted. To set scan settings for this scan type; first right click on the scan node and then left click on Node Settings to select between CDMA, GSM, WCDMA and LTE nodes. Once you click on OK, the relevant Settings menu comes up.

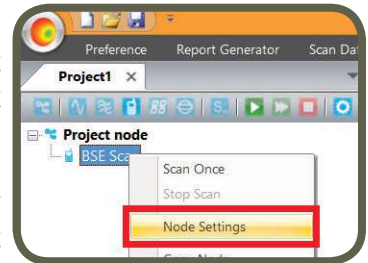

BSE General Tab

Set Cell Power and select Band.

Sweep Tab

Move on to Sweep tab to enter channel values.

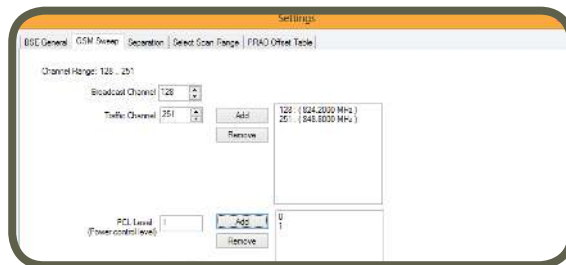
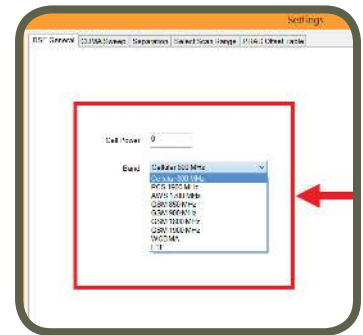

Separation Tab

Finally, enter the distance between the antenna and the surface of the scanner in millimeters or inches in the Separation tab; up to 45 mm with the RFX and 115 mm with the RFX2 as per the example below.



Select Scan Range (Near-Field Mask) Tab

Please refer to [page 62](#).

PRAD Offset Table Tab

Please refer to [page 64](#).

Typical results are shown below:

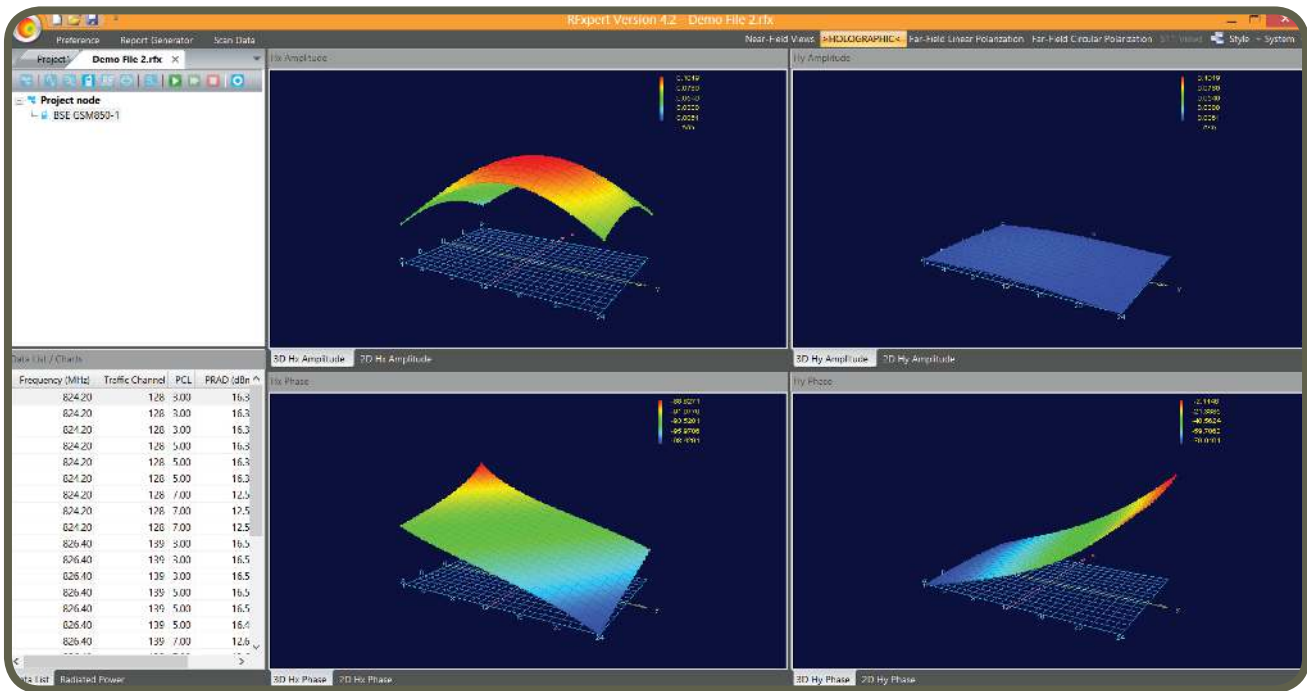

Setting up a Cell Phone Test with a Base Station Emulator

When testing a cell phone with a base station emulator (BSE), please follow these steps. You must have knowledge of how to program the phone and the BSE so that a connection can be established. Please refer to your BSE user guide for more information on your BSE settings. It is advised to use network settings that are different from live networks in your area. When using an “over the air” connection to the phone, the cell phone will not be able to differentiate between the BSE and a real network if they have the same ID settings. The best solution is for the cell phone to have a SIM card dedicated to the BSE.

Turn on the phone and place it in the middle of the scanner. Connect the RF In/Out port of the BSE to an external antenna that can support the frequencies you will be testing at. Place the external antenna close but not directly next to RFxpert. You may need to reposition the external antenna to get sufficient signal level to the cell phone. An example of a working set up is shown on the right.



Enter all of the necessary parameters into the BSE to ensure a call can be established with the cell phone. Now a signal should be present for the base station to register the mobile. If the mobile cannot detect the BSE then base station power may have to be increased. Also consider the potentially high over the air path loss which could be 20-30 dB. Once the mobile has been registered, a call can be made to the mobile.

Tip for success: If you can make a successful call then RFxpert software can complete a BSE scan. Ensure the cellphone is in an idle state and enter the parameters for a BSE scan as shown in the previous section (please refer to [page 56](#)).

Multi Co-planar Scan

Multi Co-planar Scan is available only with RFX2. EMSCAN provides trade-in option for RFX users to upgrade to RFX2. Please contact [EMSCAN](#) or your dedicated EMSCAN Sales Associate to inquire about trade-in option.

This scan type requires the phase port and the switch on the back of the RFX2.

Position A: Internal phase. This is used for regular scanning.

Position B: External phase. This is used for Multi Co-Planar scanning and [Correlation \(page 66\)](#).

Simply set press the switch to position B as shown below.

Note:
If your RFX2 is missing the phase port and the switch and you wish to use the Multi Co-Planar Scan, contact [EMSCAN](#).

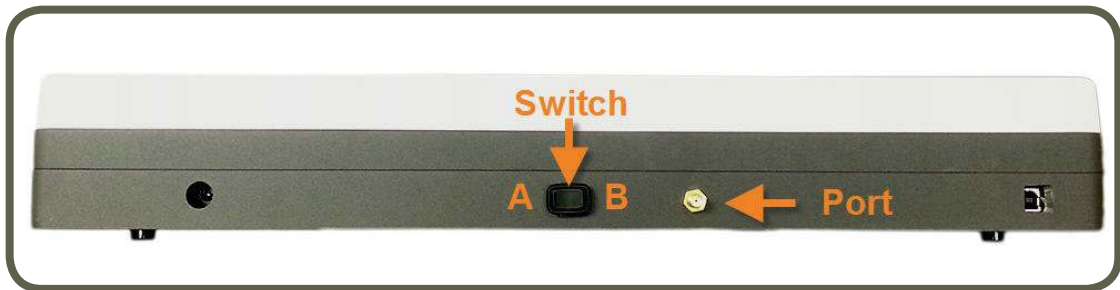

This scan option enables power and pattern measurements at a single frequency or a series of frequencies for antennas that are too large to measure with a single RFX2 scanner. This would include antennas with maximum dimensions greater than 32 cm. Multi Co-planar Scan can be set up to include a maximum of 6 x 6 covering an area of 2.40 m x 2.40 m however the maximum dimensions of an antenna that can be measured is 2.32 m x 2.32 m. This scan type can be applied to Fixed Frequency or Swept Frequency or BSE (Base Station Emulator) Scan types.

The phase port requires a reference signal that is phase coherent with the RF source being used to excite the antenna under test. For a passive antenna a splitter can be used to provide a sample of the signal source directly into the external phase port. The level into this phase port is a maximum of -10 dBm so an external attenuator will normally be required. An example of this setup for is shown below.

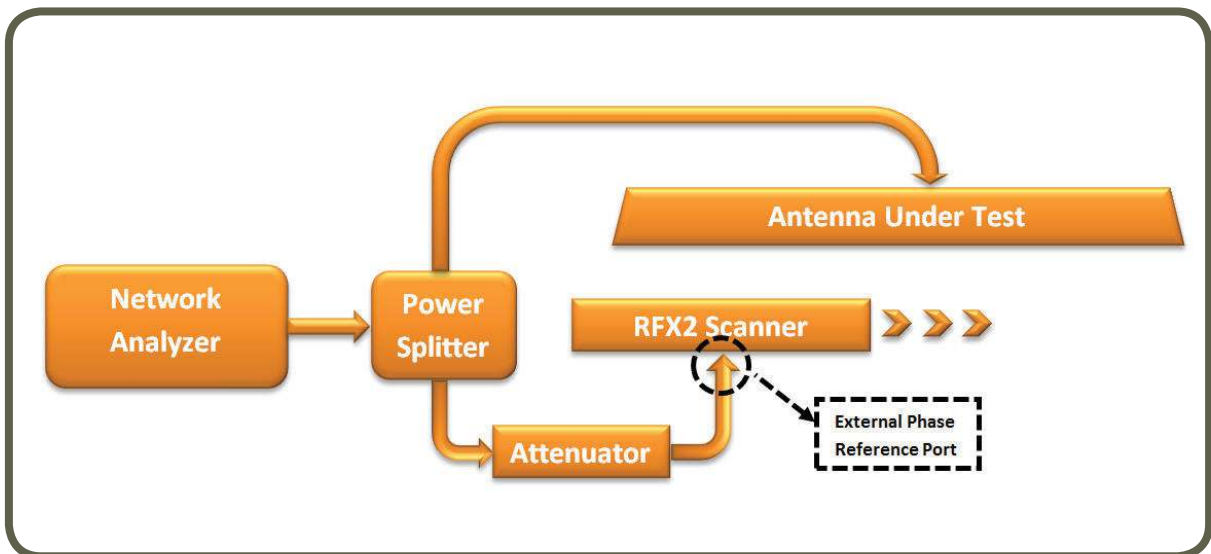

RFxpert Software Multi Co-planar Scan

For an active device the signal source is not normally accessible so an external antenna is used to provide the phase reference. The external antenna is connected directly to external phase port. This phase reference antenna should not move with respect to the antenna under test so a sufficiently long phase-stable cable should be used. The external phase reference antenna should also be placed in a location that does not interfere with the RFX2 positioning as it is moved about to sample all measurement positions. An example of this setup is shown below.

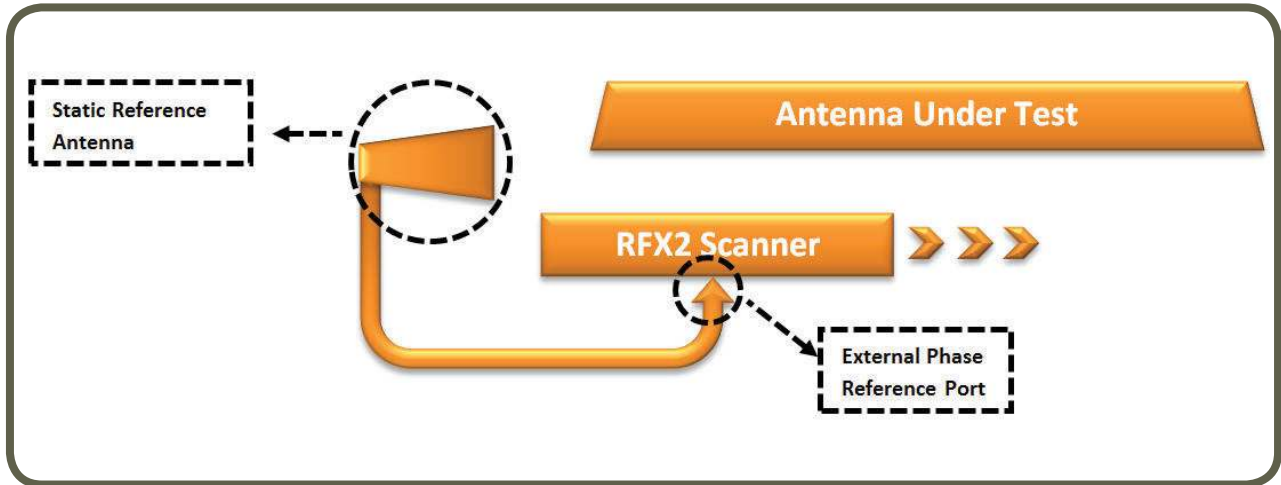

Once the phase port is set to external and the reference phase has been provided to the external phase port using the passive or active device method, you can go to scan settings.

For scan settings, first right click on the scan node and then left click on “Node Settings” to get the following screen. First select the scan type you require. For further information about the settings of the scan type, please click on the following scan type to be directed to the section in this user manual: [Fixed Frequency Scan \(page 50\)](#), [Swept Frequency Scan \(page 53\)](#), [BSE Scan \(page 56\)](#). Then, select the desired array size i.e. number of rows and columns that will be sufficient to cover the dimensions of the antenna (A). The tabs related to the scan settings (B) change to display settings for the selected scan type.

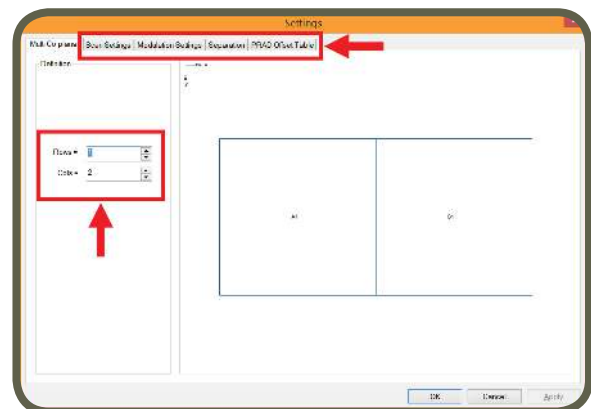
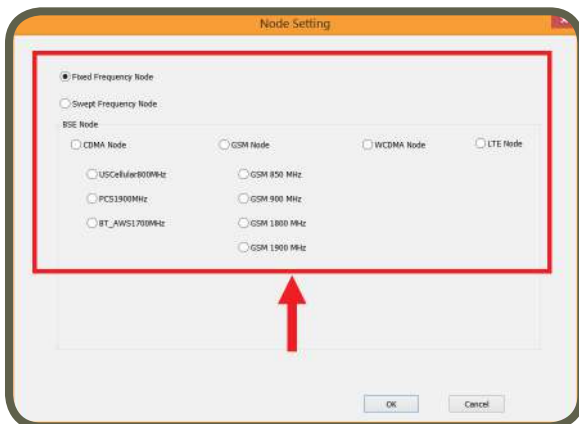
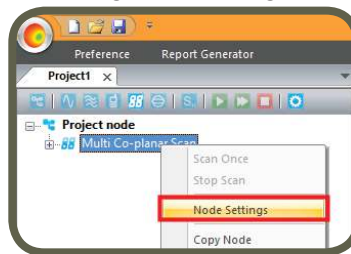

RFxpert Software
Multi Co-planar Scan

RFxpert will automatically generate subscan nodes of the selected scan type. In this example, eight Fixed Frequency Scan nodes are generated (2 rows and 4 columns).

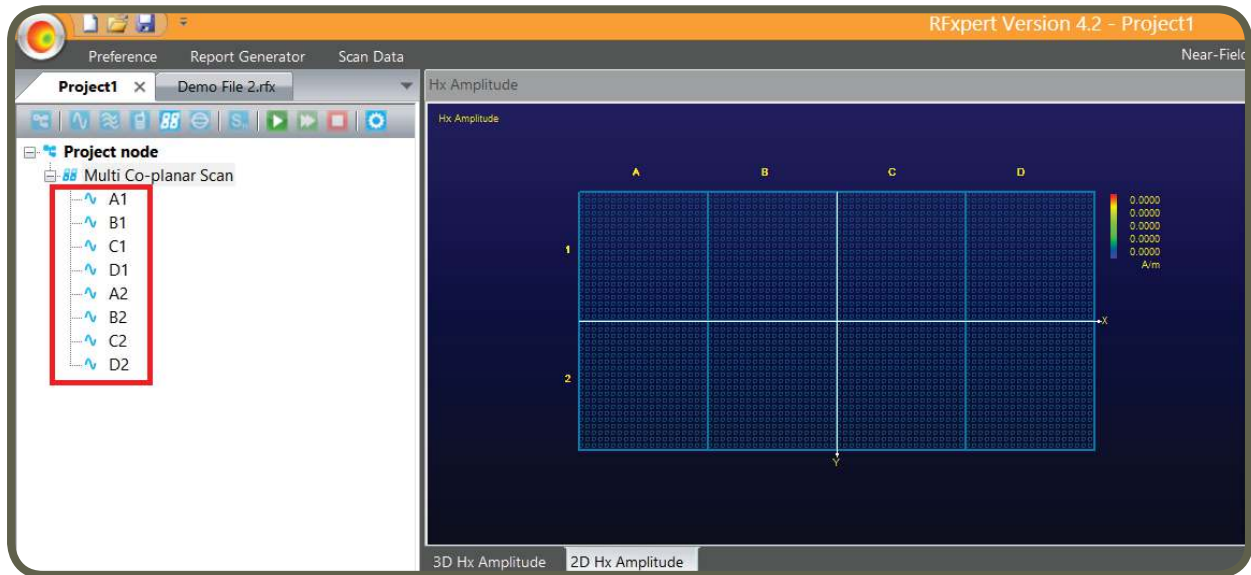

For accurate far-field results, the distance between the antenna array and the RFX2 must be constant. Ideal test condition is to suspend the antenna array above the RFX2. The MCP does not support the separation value and therefore does not change power, gain and efficiency values with increasing distance. Large antennas are typically very efficient and the uncertainty in the overall measurement added to the uncertainty in separation factors is typically less than the efficiency loss in the large antennas. If the antenna under test does have an efficiency significantly below 100% the [PRAD Offset \(page 64\)](#) feature can be used to account for any variation. This offset value must be supplied by the user.

Note:
 The Multi Co-Planar Scan does not support the separation factor feature.

Using an absorber material to cover the RFX2 may be helpful in minimizing the impact of manually moving the RFX2 to each subsequent position in 40 cm increments. If the movement of the RFX2 scanner influences the antenna, it is possible to reduce the effect by placing absorber between the RFX2 scanner and the antenna under test. To verify whether the scanner is being influenced, the reflection (S_{11}) into the scanner should be monitored. If the reflection changes significantly between successive positions of the RFX2 in a Multi Co-planar Scan then absorber may be required.

To account for absorber the PRAD offset feature should be used. An amount equal to the loss in the absorber can be entered into the software. A quick measure of the loss can be done with a measurement of the near field using the RFX2. One measurement with absorber present and one with the absorber not present.

Position the RFX2 corresponding to A1 under the suspended antenna array. Select A1 and then click 

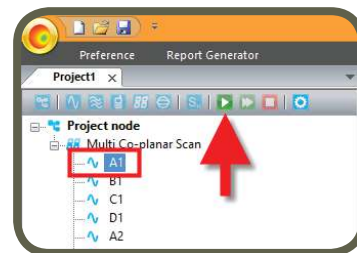
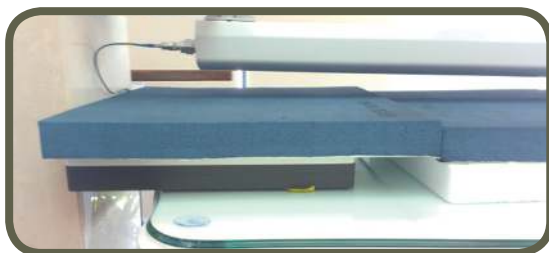

Note:

The MCP node does not have NFW window capability because truncation at the edges can be dealt with by making the scan area larger. With a sufficiently large scan area, the NFW capability will have no added benefit. In fact this method will produce better pattern results than a smaller area with NFW active.

Once the scan is completed, move the RFX2 exactly 40 cm in the y direction to position A2. Select A2 and then click 

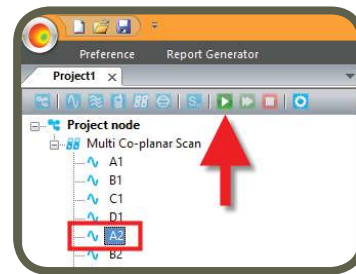
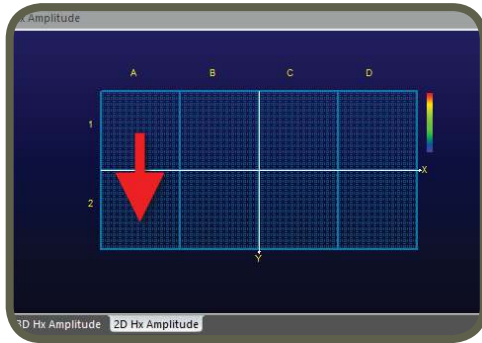

Repeat these steps until the first column is done. Return the RFX2 to the beginning position and then move it exactly 40 cm in the x direction to position B1. Run a scan for the first subnode of the second column in position B1.

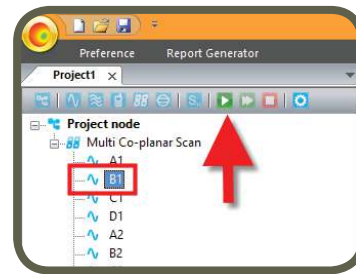
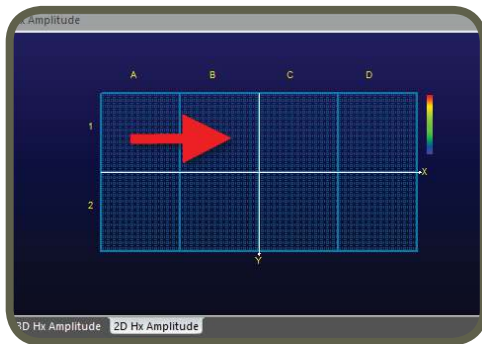

Repeat the movement in the y direction while running a scan every 40 cm at the appropriate node until all rows and columns are scanned. When all subscans are completed the parent node (Multi Co-Planar Scan) should automatically update. To view the results, first click on the parent node and then select the view: near-field or far-field.

Note:

When changing any setting of the parent node like number of rows or columns or frequency settings, all results will be lost. When running the scan again all current results will be lost even for a fixed frequency scan.

Near-Field Measurement Mask

In all of the scan types except Multi Co-planar Scan there is the option to filter out or mask the near-field. This can help the user remove the effects of currents on cable or secondary radiators from the predicted far-field results. To apply the mask go to the node settings of the selected scan type and click Select Scan Range tab.

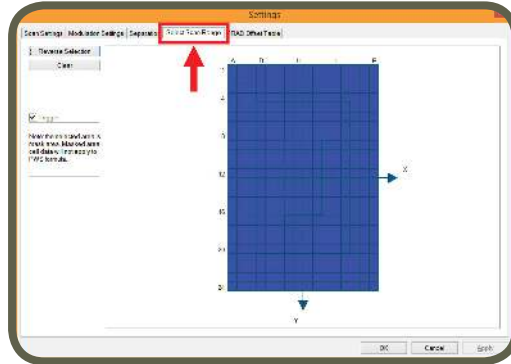

The default selection is to have the entire scan but the user can select areas by clicking or dragging the cursor on the scan area image. These selected areas are shown in yellow and will not be included in the far-field transformation. Until clicking Apply, the mask will not be applied to the next scan. After making changes to the mask and clicking Apply the mask will be stored and used for the next measurement.

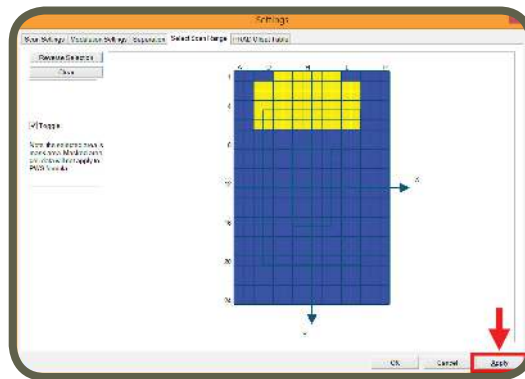

Clear button will remove the selection.

To create a mask, you select an area. To mask the area that is not selected simply click Reverse Selection.

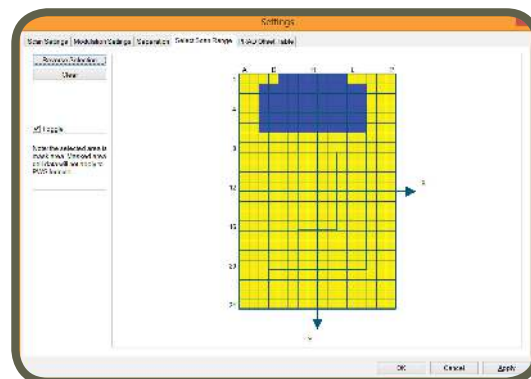
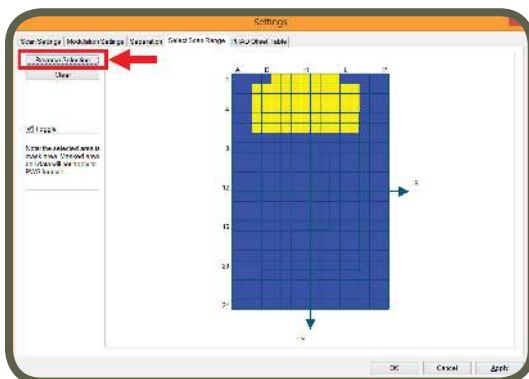

RFxpert Software Near-Field Measurement Mask

If you want to add selections to already selected area then uncheck the toggle option. Otherwise, the selection will simply switch back and forth between selected and unselected.

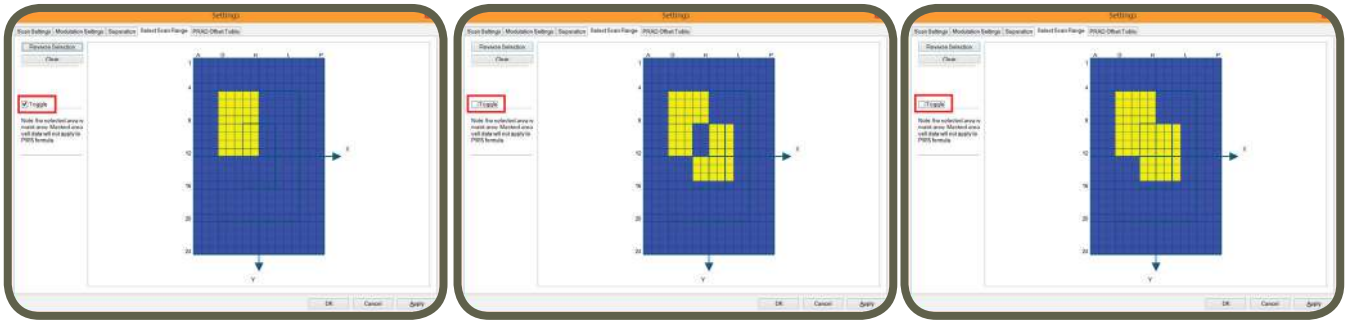

An example of using the measurement mask is shown here. You can see the mask settings as well as the impact it has on the near-field results. The masked area will never show up in the far-field pattern.

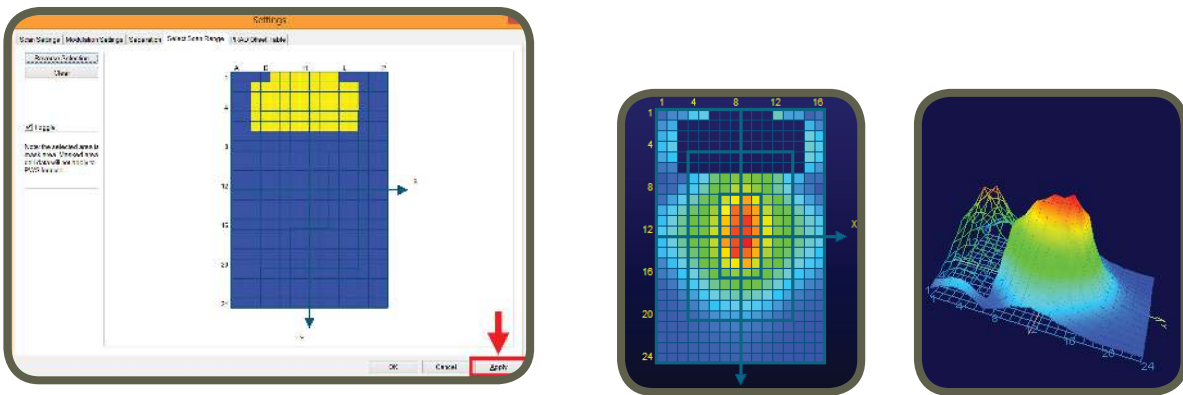

PRAD Offset Table

The RFxpert system can provide accurate and repeatable measurements of PRAD (TRP for 2 hemispheres). Sometimes, these repeatable measurements have a small but measurable offset from other measurement techniques like an anechoic chamber. In this situation the software can support a user defined offset to force the results of the RFxpert to be very similar to those the user wishes to emulate.

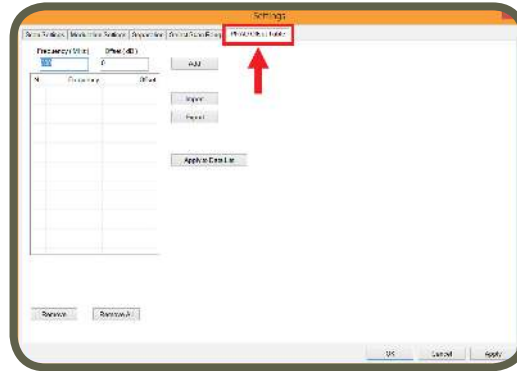

To use this feature simply enter the frequency and offset value you wish to be applied to the measured PRAD (TRP) value. A negative value entered in the offset column will cause the measured values to be lower. All derived values like efficiency and gain will also be affected. If you are using a range of frequencies a list can be entered with different offsets at each frequency. For values between list elements, first order interpolation will apply. You must click “Apply to Data List” before any change will be made to the results. If you edit the list and click “Apply” the values for existing measurements and future measurements will be affected.

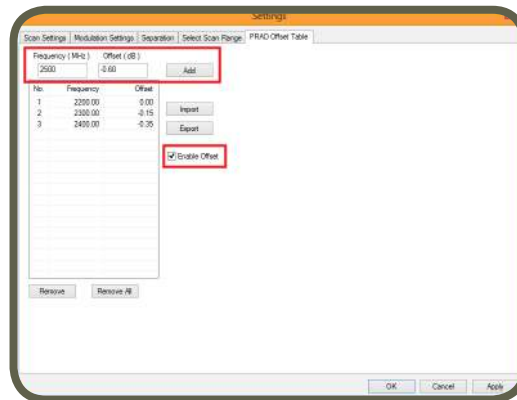

You can remove any value from the list or remove the entire list at any point. After removing a point or the entire list you must click “Apply” before the changes will impact any existing data.

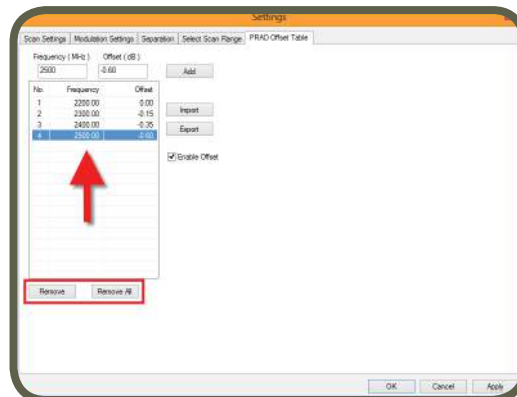

RFxpert Software PRAD Offset Table

You can export the offset list from the RFxpert software, edit it and re-import or import a list which was created in another application. To do this use the “Import” and “Export” buttons. The list will be exported to a text file which is a comma separated list of frequency and offset value. The list will be comprised of one frequency per line with values in the operation range of the RFxpert.

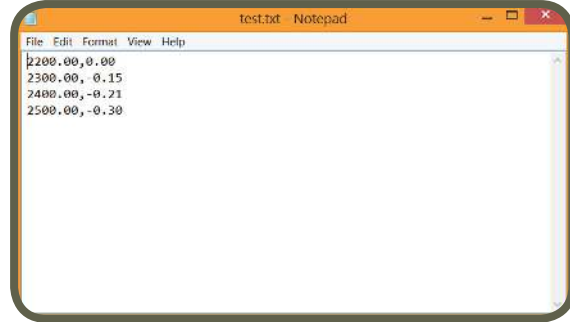
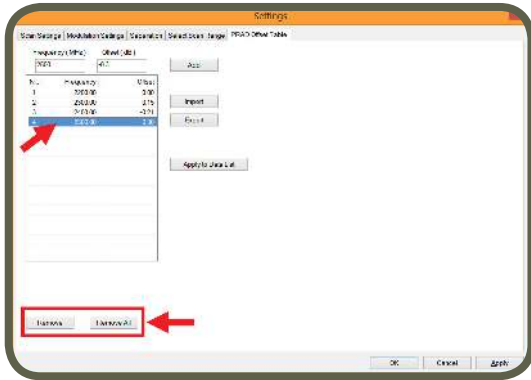

Comparing Scan Results

Correlation

The correlation measurement, also known as antenna correlation or pattern correlation, is a measure of how similar two patterns are. This is used in MIMO systems in order to maximize data throughput.

The correlation measurement only applies to two patterns at a time and is only visible when comparison mode has been enabled.

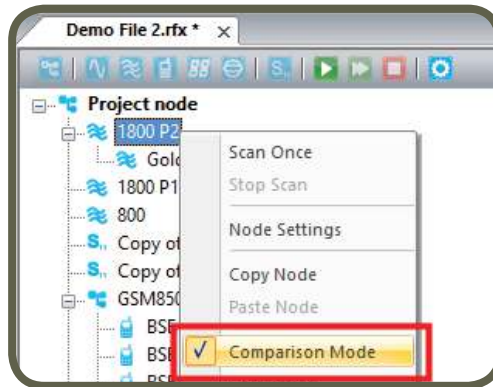

For one hemisphere, both RFX and RFX2 can provide a correlation measure.

For a full spherical result it is important that the two hemispheres have phase coherence. This requires using the external phase feature (please refer to the RFX2 image on [page 58](#)) which is only available on the RFX2.

For each antenna the two hemispheres must be measured with the external phase reference in use. This means the exciting signal must be fed into the external phase port.

The two separate antennas do not need to be phase coherent and do not need to be connected in any way.

Once two patterns have been measured executing a comparison between them will automatically display the correlation between the two patterns in the Far-Field view of the pattern.

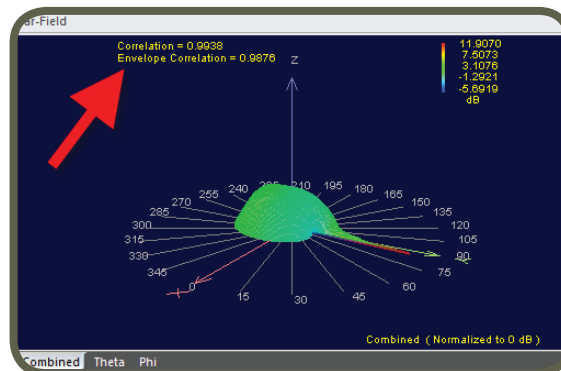

Fixed Frequency Scan Comparisons

(One or several individual measurements which may be at the same or different frequencies)

Two options:

1. Compare a single sample in a data list with all of the other samples in the same list
2. Compare a single sample in one data list (node) with all the samples in another data list (node)

It is also possible to use a combination of these to compare a collection of Fixed Frequency Scans during a product verification of sample lot testing process (Please refer to [Appendix page 83](#))

Compare a single sample in a data list with all of the other samples in the same list:

- Select a Fixed Frequency Scan and left click on the scan to expose the data list

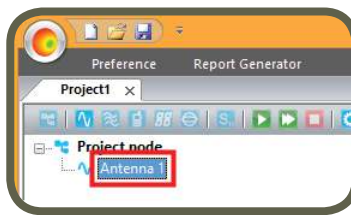

- Go to the row in the data list that you want to set as the golden sample. Right click on the row and left click Mark As Golden Sample

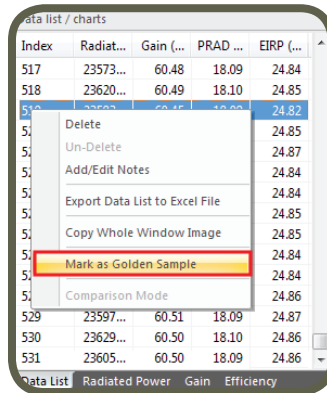

- This will automatically create a golden sample node immediately below the scan node. It will also automatically change the mode into Comparison and present a revised data list which shows the comparison

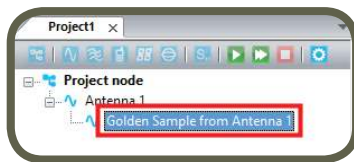

Index	Frequenc...	ΔPRAD (...)	ΔEIRP (dB)
1	2448.00	0.01	-0.00
2	2448.00	0.01	-0.07
3	2448.00	0.00	0.00
4	2448.00	0.06	0.03
5	2448.00	-0.01	-0.04
6	2448.00	0.05	0.05

RFPert Software Comparing Scan Results

- To undo the comparison, right click on that row again and left click to uncheck the Comparison Mode

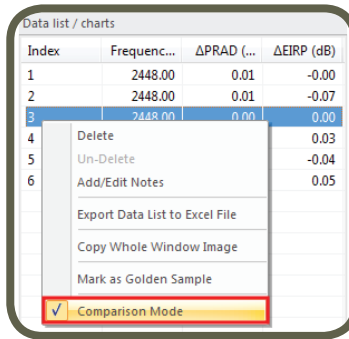

- To delete golden sample, right click on the golden sample and select delete node

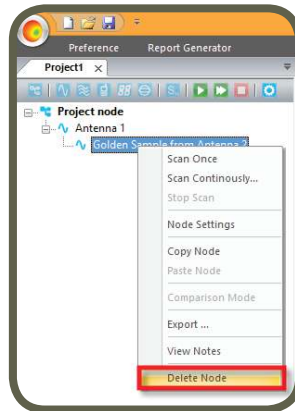

Compare a single sample in one data list (node) with all the samples in another data list

There are two ways to do this. The easiest and most intuitive way is:

- Select a Fixed Frequency Scan and left click on the scan to expose the data list

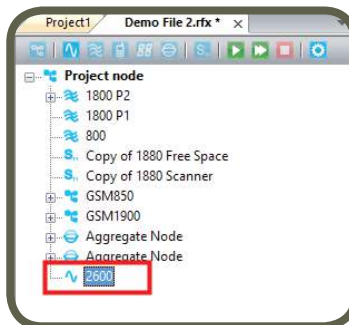

- Go to the row in the data list that you want to set as the golden sample. Right click on the row and click Mark As Golden Sample

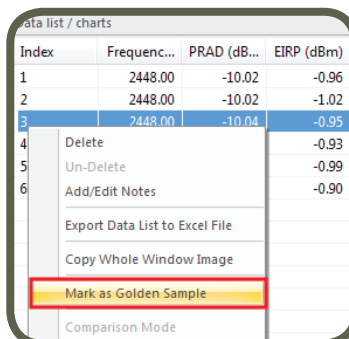

RFxpert Software Comparing Scan Results

- This will automatically create a golden sample node immediately below the scan node.

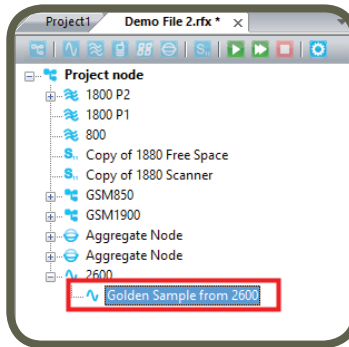

- Drag this golden sample node and drop it onto the Scan with which you want it compared.

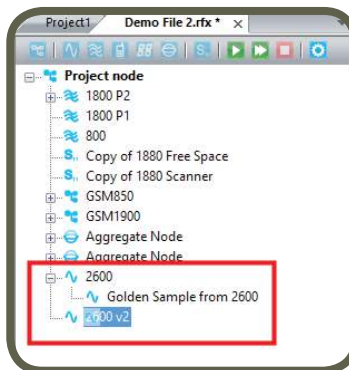

- This will automatically create a golden sample node below that scan node, change the mode into Comparison Mode, and modifies data list to show the comparison.

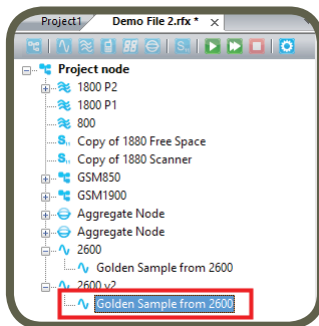

Index	Frequency (...	Δ PRAD (dB)	Δ EIRP (dB)
1	2448.00	0.01	-0.00
2	2448.00	0.01	-0.07
3	2448.00	0.00	0.00
4	2448.00	0.06	0.03
5	2448.00	-0.01	-0.04
6	2448.00	0.05	0.05

Data List / charts
Radiated Power

- To undo the comparison, right click on the scan node and left click to uncheck the Comparison Mode.

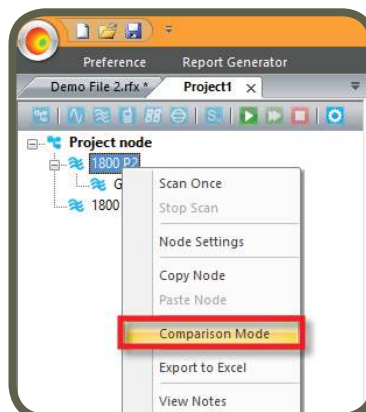

Swept Frequency Scan Comparisons

Two options:

1. Compare a single sample in a data list with all of the other samples in the same list
2. Compare all samples in one data list (node) with all the samples in another data list (node)

Compare a single sample in a data list with all of the other samples in the same list:

The approach here is identical to that described for [Fixed Frequency Scan Comparisons \(page 67\)](#).

Compare all samples in one data list (node) with all the samples in another data list (node)

- Select the scan node you want to be the golden sample, right click on this node and select “Copy Node”

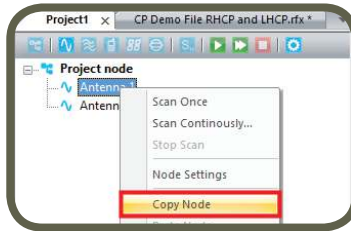

- Select the scan node you want to compare to the golden sample, right click on this node and select “Paste Node”

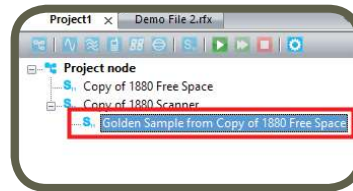
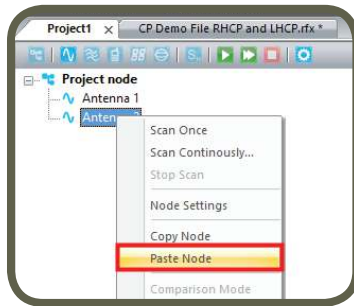

- This will automatically create a golden sample node below the node you want to compare with it and change the mode into Comparison Mode and modifies data list to show the comparison

Note:

- o The comparison table will only compare and show rows with common frequencies.
- o If there are no common frequencies on two lists, the created comparison list will be empty.

S₁₁ Scan Comparisons

Three options:

1. Compare a single sample in a data list with all of the other samples in the same list
2. Compare all samples in one data list (node) with all the samples in another data list (node)
3. Compare a single sample in one data list with all samples in another data list

RFExpert Software Comparing Scan Results

Compare a single sample in a data list with all of the other samples in the same list:

The approach here is identical to that described for [Fixed Frequency Scan Comparisons \(page 67\)](#).

Compare all samples in one data list (node) with all the samples in another data list (node)

The approach here is identical to that described for [Swept Frequency Scan Comparison \(page 70\)](#). It is also possible to create a superimposed plot a golden sample S_{11} list with another S_{11} list. To do this:

- Once you've created the comparison of two lists, the graphs of Amplitude and Phase will show the resultant comparison
- Place the cursor over the graph, right click and uncheck Comparison Mode

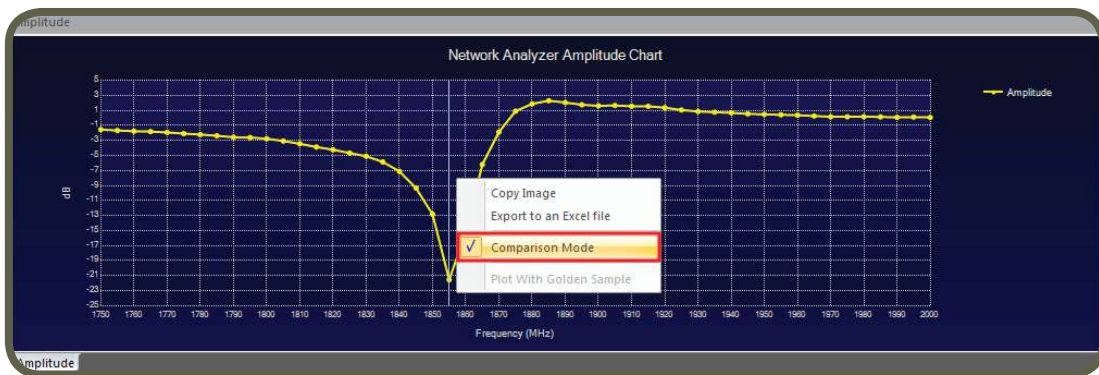

- Right click again and left click to select Plot with Golden Sample

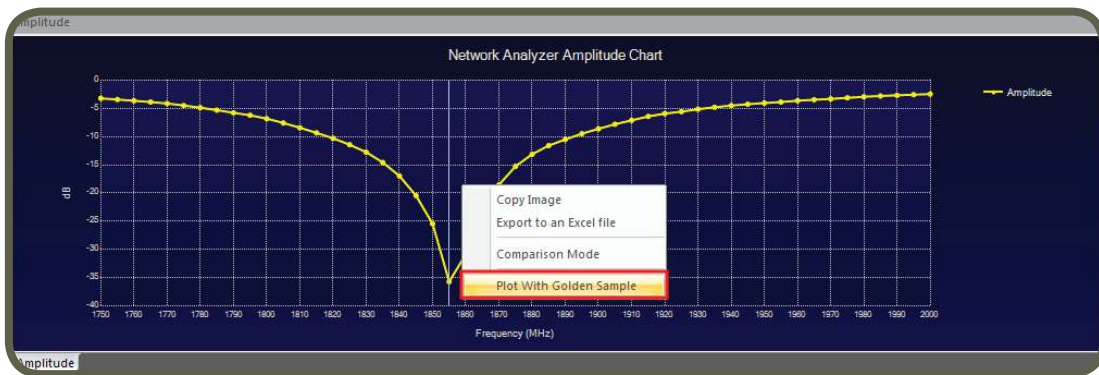

- Two plots of the S_{11} scans will be superimposed with the red plot being the golden sample

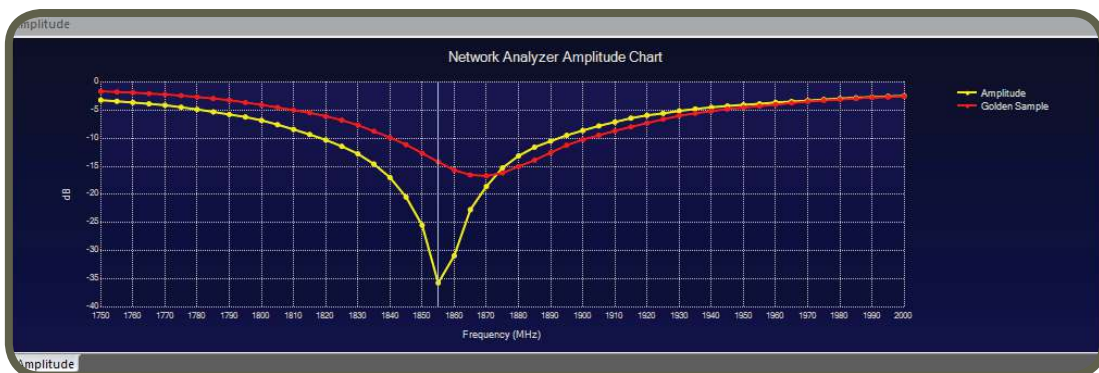

Aggregate Node

Aggregate node is used to combine scanning results based on frequency to have full spherical far-field view. It can be used for Fixed Frequency Scan, Swept Frequency Scan data and Base Station Emulator Scan data.

The following settings must be the same

Fixed Frequency Scan:

- Number of scans
- Scan frequency

Swept Frequency Scan:

- Number of scans
- Start and stop frequencies
- Single point frequencies

Base Station Emulator Scan:

- Number of scans
- Band type
- Traffic channel
- PCL levels

How to Position the DUT on the Scanner

DUT should be positioned along the Y-axis of the scanner to ensure the aggregate node combines them together properly. First, scan one side and then flip the DUT, around the Y-axis and run another scan.

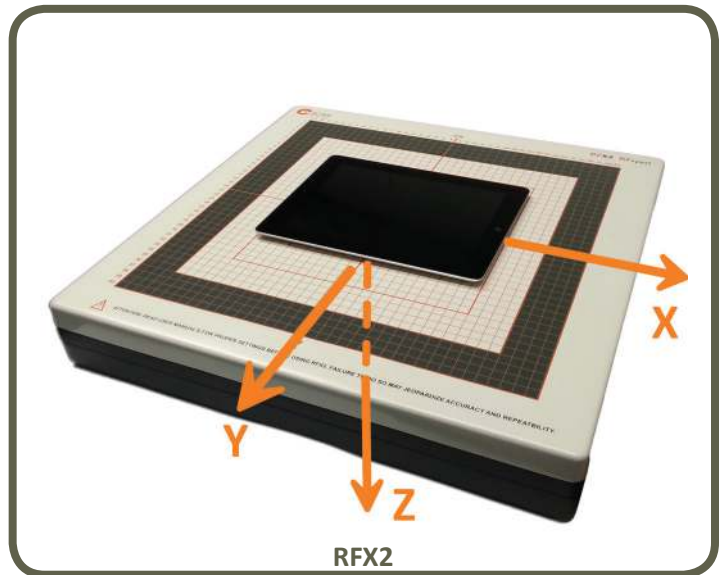
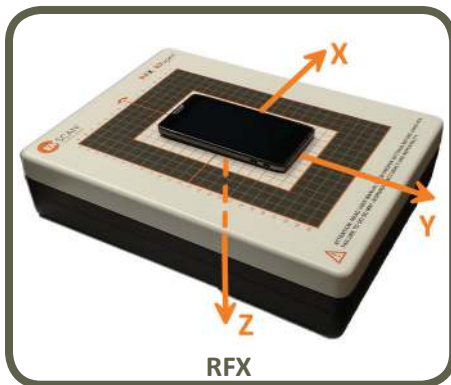

RFxpert Software Aggregate Node

To form an Aggregate Node

- Right click on Project node, and choose Aggregate Node or just click Aggregate Node icon  on the task bar.



- Select the scan type that you want to aggregate (Fixed Frequency, Swept Frequency or BSE), right click on the node and select Copy Node, right click on Aggregate Node and select Paste Node or drag and drop the node under Aggregate Node.

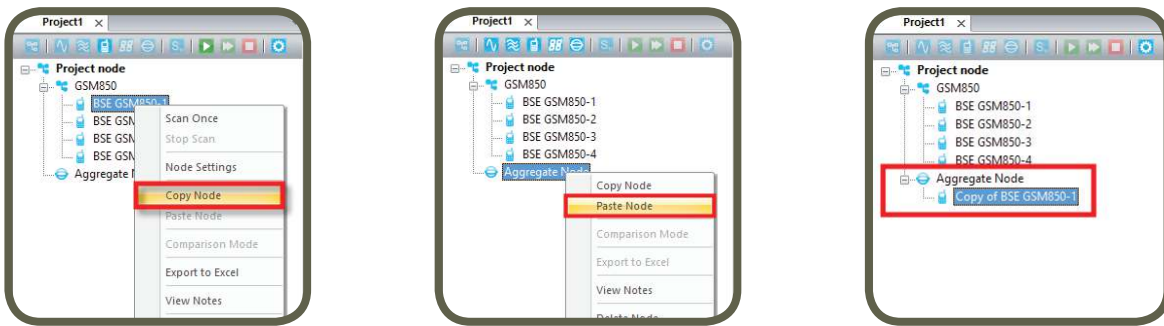

- Aggregate Node will automatically create a combination of the two scan results in the Aggregate Node window. See example below:

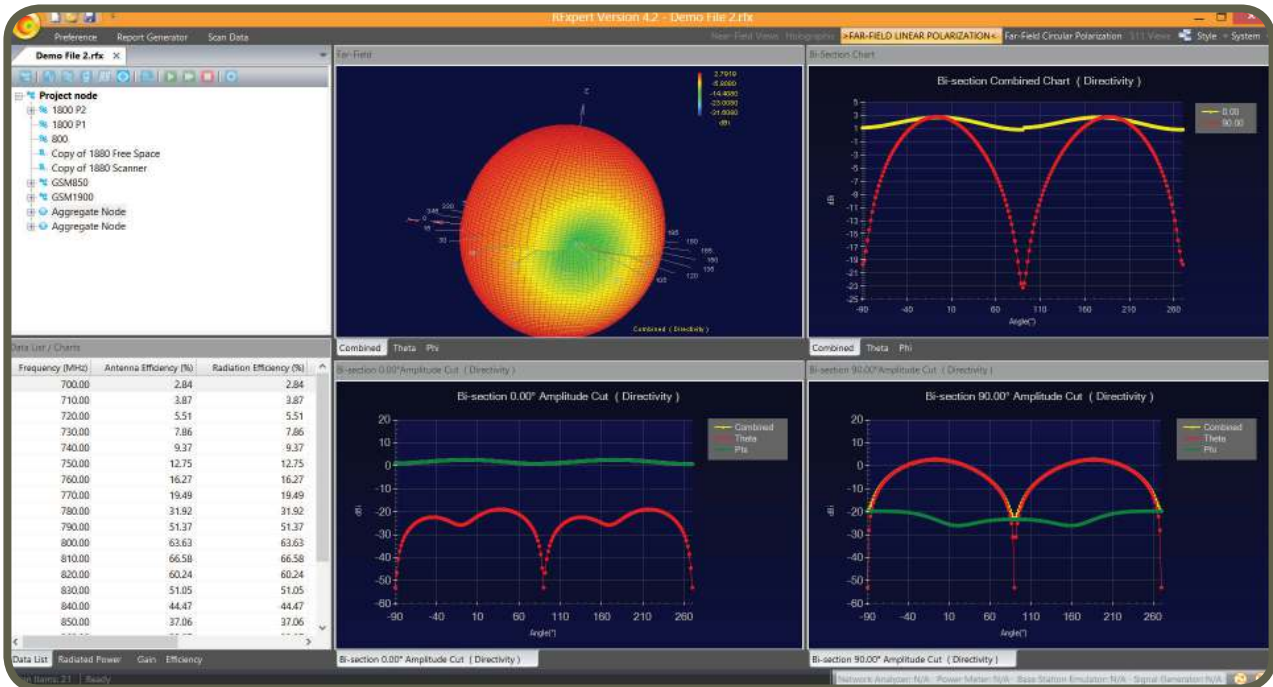

What is displayed is a full slice through the sphere that reflects a merging of two hemispheres (one for each side of the DUT). This merging will also apply to Bisection Polar View – Theta; and Bisection Polar View – Phi. TRP is also calculated.

Application Notes: Network Analyzer for S_{11} and Swept Frequency Scans

Network Analyzer Calibration: S_{11} and Swept Frequency Scans

- S_{11} Measurements

The standard network analyzer (NA) calibration must be done to get reliable S_{11} results. Otherwise S_{11} data itself could have large errors (3-4 dB and +/-180 degrees).

Note: Please see [Appendix “How to connect Power Meter and Network Analyzer” \(page 85\)](#).

- Swept Frequency Measurements

Since the VNA is a device which makes ratio-ed measurements by design it does not control the output power level very closely. Depending on the model you can have power fluctuations of 0.5 dB to 5 dB. The calibration referenced above does not address the source power variance. For efficiency and gain calculations, we need to know the absolute power level directed towards (and into) the feed point because we are comparing those to the absolute radiated power. Please refer to [Appendix “How to connect Power Meter and Network Analyzer” \(page 85\)](#) for reliable efficiency and gain measurements/calculations.

- Base Station Emulator Scan (BSE)

When measuring a cell phone with the BSE node care must be taken to ensure the ‘live network’ is not interfering with your phone. This would include modifying the roaming list (PRL) of the phone or using a dedicated SIM card. An over the air link between the BSE and the phone must be provided with an external antenna. If there are problems in establishing a call make ensure that you can manually connect to the phone first with the same physical setup. To ensure reliable results make sure that CDMA phones are only measured at maximum power. To do this, set the requested power on the BSE higher than the phone can deliver or set the power control to all up bits.

See the link for supported [Base Station Emulators \(https://www.emscan.com/products/antenna-testing/rfx2/\)](https://www.emscan.com/products/antenna-testing/rfx2/).

Connection Accessory Requirements

- For instruments requiring GPIB connection we use National Instruments (NI) ‘PCI-GPIB’ or preferably the Agilent 82357B USB/GPIB adapter model to connect. The interface should support most NI GPIB interfaces that NI claims to be compatible.
- See the link for supported [Network Analyzers \(https://www.emscan.com/products/antenna-testing/rfx2/\)](https://www.emscan.com/products/antenna-testing/rfx2/).

Copper Mountain S5048 and PLANAR 808/1 Setup

1. Connect the Copper Mountain S5048 to your PC and power it up.
2. Click [here \(http://www.coppermountaintech.com/download/172/S2-Software-Installer-br-v17-2-5-June-6-2017-/\)](http://www.coppermountaintech.com/download/172/S2-Software-Installer-br-v17-2-5-June-6-2017-/) to install the S2VNA software for S5048 and click [here \(http://www.coppermountaintech.com/products/14/808/\)](http://www.coppermountaintech.com/products/14/808/) to install S4VNA for PLANAR 808/1. During the installation select register COM server. Please see following instruction in the programming manual.

Registering COM Server

To register COM server of the analyzer run the executable module from command prompt with the /regserver keyword. To unregister COM server of the analyzer run the executable module from command prompt with the /unregserver keyword.

Administrative rights is required to register/unregister COM server. Also user has ability to register COM server during the software installation procedure.

Example of the COM server registration command:

S5048.exe /regserver

Open the S2VNA/S4VNA software ➔ Select Main Menu S5048 ➔ select System ➔ Misc Setup ➔ Network Setup ➔ Set Socket Server ON and TCP/IP Port to 5025

3. Install the Keysight IO Libraries Suite (please refer to [page 14](#)). Please ensure that Keysight VISA is [PRIMARY \(page 25\)](#). Check the bottom right of your IO Libraries Suite.
4. Before launching the RFxpert application SW, launch the Copper Mountain S2VNA/S4VNA software

Frequently Asked Questions (FAQ)

1. [How do you provide an accurate EIRP estimate despite the fact that only one side of DUT is measured?](#)
2. [How fast is the full measurement cycle?](#)
3. [When measuring GSM power, how do we address duty cycle?](#)
4. [How do we measure transmitters with rapidly changing power levels?](#)
5. [What is the measurement sensitivity for accurate power measurements?](#)
6. [Are the measurements reliable in noisy ambient environments without an anechoic enclosure?](#)
7. [Can you measure multiple antennas on different planes?](#)
8. [What kind of power supply can be used?](#)
9. [What is the range of supported power levels?](#)
10. [Where do I place the DUT?](#)
11. [What is the accuracy of RFxpert measurements?](#)
12. [I have a network analyzer that is not on the list of supported analyzers, can it still be supported?](#)
13. [What are the minimum system requirements?](#)
14. [What is the maximum power level that RFxpert can receive without being damaged?](#)
15. [What are the effects on the measurement from driving the antenna with lower power \(e.g. dBm vs. 20 dBm\)?](#)
16. [The features/specifications indicate measuring dipoles and helical antennas. I assume that this is done by laying the DUT flat on the scanner bed? How do you feed the antenna without having the cable on the scanner bed, without some sort of de-embedding? Both of these conditions would seem to compromise the integrity of the near-field and alter the measurement accordingly.](#)
17. [When selecting "Pattern Settings Properties", "Amplitude Scale", "Comparison Type", switching from linear to Log10 seems to have no effect. What is this supposed to do? I thought it changed the scale of the near-field and far-field patterns.](#)
18. [If I put my cell phone on the scanner, does it scan?](#)
19. [How can I measure each side of the DUT in order to get a full spherical pattern?](#)
20. [Can RFxpert be integrated into existing test applications or simply automated to provide faster measurement results?](#)
21. [Why am I getting low power warning? How can I test an antenna while getting low power warning?](#)
22. [What is the resolution bandwidth of RFxpert?](#)
23. [What is the RFxpert TIS proxy?](#)

1. How do you provide an accurate EIRP estimate despite the fact that only one side of DUT is measured?

Effective Isotropic Radiated Power (EIRP) is the power that has to be supplied to an isotropic antenna to achieve the same maximum far-field strength. EIRP is determined traditionally by identifying and measuring the peak radiated value on the surface of the “measurement sphere”. For directive antennas, by measuring radiation in the main hemisphere there will be no difficulty in identifying and precisely measuring the peak value. So even if you had other devices under test that were not so specifically dominant in one direction, you could still accurately estimate the EIRP value. What gets potentially compromised in scanner measurements for omni directional sources is accurate far-field pattern. Radiated power (PRAD) is obtained by integrating power density (obtained from the NF to FF transform) over the hemisphere. So in the worst case when only measuring one side, the TRP error is 3 dB. Both “sides” can be measured and the power sum taken, to get accurate TRP. As a design tool, differential changes on the peak side (or the weak side in the case of SAR optimization) are probably all that are necessary for optimizing.

2. How fast is the full measurement cycle?

Each measurement including processing and display takes 1 second on the RFX and 4 seconds on the RFX2. RFxpert collects the data in 40 milliseconds and then the PC may require an additional 1 second to process and display the data. The overall measurement time can be reduced to 300 milliseconds for a simple go/no go scan result (e.g. measuring EIRP against a spec limit). In TDMA mode the scan time will be longer, due to the fact that the system must wait for a pulse to appear. Currently, the total scan time for a GSM phone is approximately 3 seconds on the RFX and 12 seconds on the RFX2.

3. When measuring GSM power how do we address duty cycle?

We tested GSM sources at 1/8 duty cycle. At 1/8, it slows down the process. GSM has a 500 μ s pulse. The system waits for the rising edge to level out and then measures it.

4. How do we measure transmitters with rapidly changing power levels?

RFxpert requires the power level to remain constant for 40 ms. If it is less than 40 ms, power level measurements will not be reliable.

5. What is the measurement sensitivity for accurate power measurements?

RFxpert can measure a minimum source power of 0 dBm for a reasonable antenna.

6. Are the measurements reliable in noisy ambient environments without an anechoic enclosure?

In testing of active antennas using a BSE, we put an intentionally radiating device 30 cm away from the scanner and it did not compromise the cell phone results. If the interfering element is 20 dB higher than a DUT and no closer than 1 meter from the RFxpert, the effect is minor. In more extreme cases where there is predictable interference, frequency and level coordination can be used. For adjacent test systems operating at very different power levels, frequency discrimination isolates the measurement systems. The scanner and DUT do not need to be put into an “anechoic” enclosure.

7. Can you measure multiple antennas on different planes?

Yes. This can be done if you know the location of each antenna on the DUT, their locations in relation to the sensors, and if each antenna can be excited individually and not all on at the same time. The measured data will then be adjusted based on distance tables.

8. What kind of power supply can be used?

Use the 6 VDC power supply for RFX and 12 VDC for RFX2 that is shipped with the system only. It is an universal 50/60 Hz and 100 v/240 v converter.

9. What is the range of supported power levels?

The supported power level range is from +33 dBm to 0 dBm. There is no risk in running RFxpert with less than the minimum supported power. RFxpert software will indicate if the signal level is too low to be detected or measured accurately. For power levels greater than +40 dBm, RFxpert may be damaged.

10. Where do I place the DUT?

To test a device it should be placed on the scanner. The device should be placed with the radiating surface down, and ideally positioned in the white area. The maximum device size can be larger than the scan area, but the radiating surface should be small enough to fit in white scan area (depicted by blue arrows in below picture).

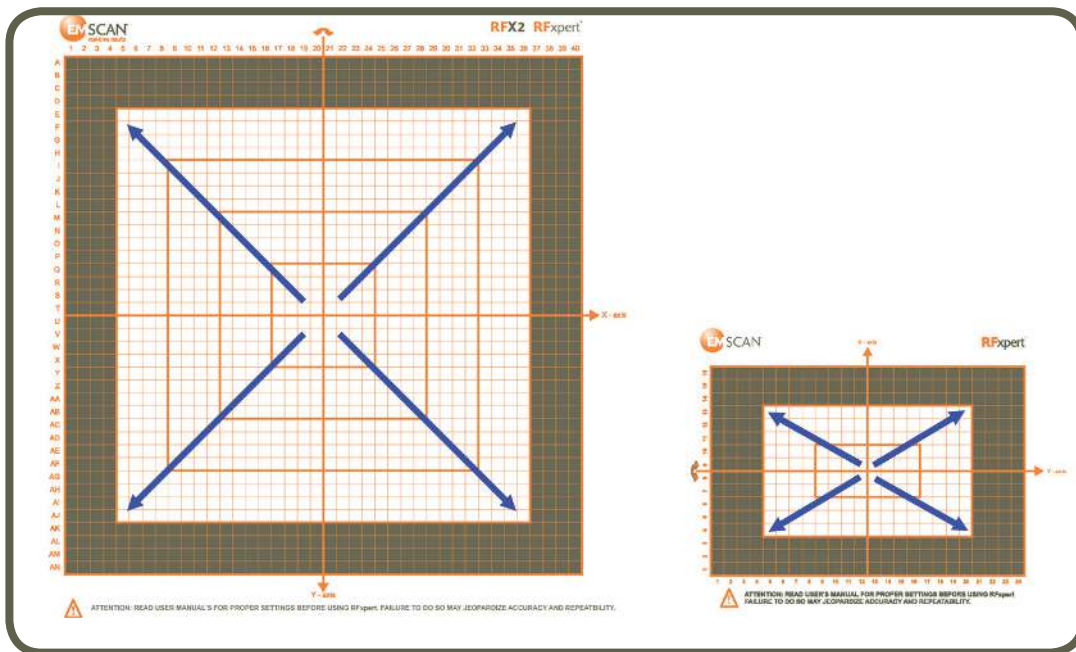

11. What is the accuracy of RFxpert measurements?

Current accuracy values for a calibrated RFxpert with the latest configuration file are summarized as follows:

	<1GHz		1GHz-3GHz		3GHz-6GHz	
	σ	N	σ	N	σ	N
RFX	1.96	170	0.81	514	1.1	246
RFX2	1.54	195	0.81	517	0.94	247

σ is the standard deviation of measurement error
 N is the number of measurement samples at the band

For even more details on accuracy, look at the following error distribution of the RFX2 measured efficiencies compared to chamber data:

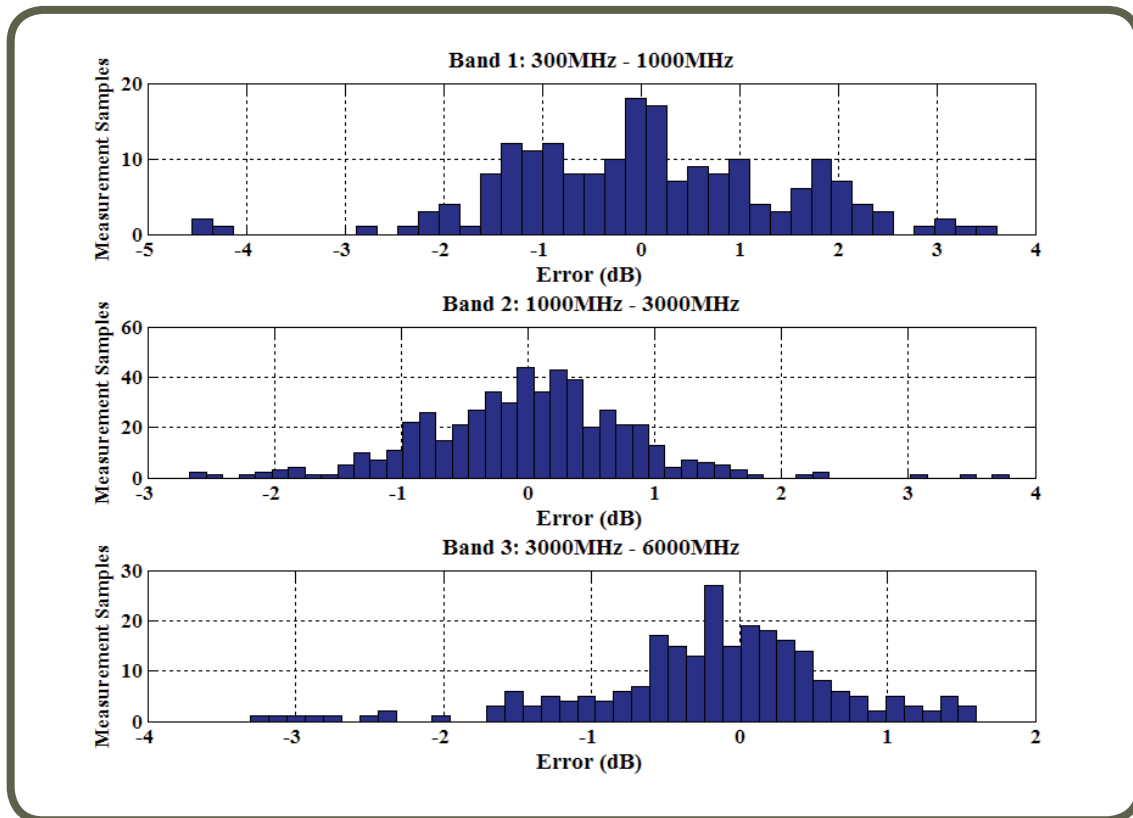

12. I have a network analyzer that is not on the list of supported analyzers, can it still be supported?

If your network analyzer is not on the supported network analyzer list, please contact your local representative or EMSCAN at info@emscan.com for details.

13. What are the minimum system requirements?

Intel Core, 3.2 GHz, 1 GB RAM recommended. Windows XP SP3 OS and a CD ROM Drive.

14. What is the maximum power level that RFxpert can receive without being damaged?

The maximum power level for accurate measurement is approximately +33 dBm into the antenna. Damage may occur above +40 dBm.

15. What are the effects on the measurement from driving the antenna with lower power (e.g. 0 dBm vs. 20 dBm)?

As long as the power received at the reference probes is high enough, there should be no change other than a lower power level. As the source power goes out of range, you will start to see phase errors first which will influence far-field results.

16. The features/specifications indicate measuring dipoles and helical antennas. I assume that this is done by laying the DUT flat on the scanner bed? How do you feed the antenna without having the cable on the scanner bed, without some sort of de-embedding? Both of these conditions would seem to compromise the integrity of the near-field and alter the measurement accordingly.

The system always provides measurement results as is, in the near-field. If a cable is present, then very often currents can be seen on it. The onus is on the tester to set up the conditions so as best to represent what they want to measure. If the cable cannot be moved away from the scanner surface then absorbing foam may help to reduce the impact on the test.

17. When selecting “Pattern Settings Properties”, “Amplitude Scale”, “Comparison Type”, switching from linear to Log10 seems to have no effect. What is this supposed to do? I thought it changed the scale of the near-field and far-field patterns.

The linear/log switch applies to the difference mode of the comparison scan. When comparing the near-field of two scans that have different power output, it is often more instructive to compare the fields in a log sense

18. If I put my cell phone on the scanner can I measure its performance?

You cannot measure your cell phone since it is being managed by a live network. The output power and transmit times are too variable to get a good measurement. However, if you were to connect to your phone using a base station emulator, RFxpert will be able to measure it accurately.

19. How can I measure each side of the DUT in order to get a full spherical pattern?

Refer to [Aggregate Node \(page 72\)](#). The DUT should be rotated around the Y axis of the scanner for the second measurement. This will ensure the aggregate node combines them together properly.

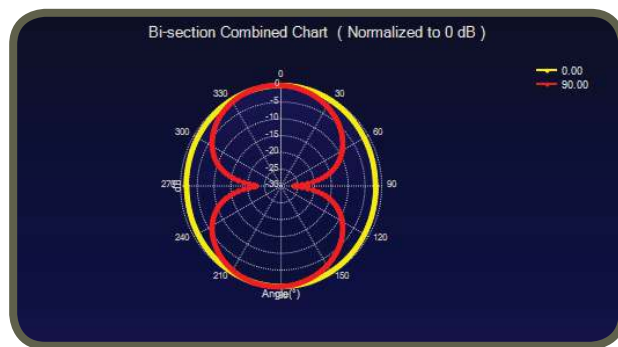
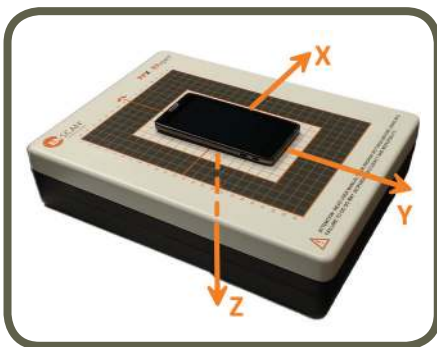

20. Can RFxpert be integrated into existing test applications or simply automated to provide faster measurement results?

RFxpert system can be easily integrated into existing test applications or simply automated to provide faster measurement results. This is done by accessing the API of RFxpert dll. There is a documented installation package included with RFxpert installation CD in RFxpertDLL folder. This package includes a sample program to remotely control RFxpert. For more information please contact [EMSCAN](#) Technical Support.

21. Why am I getting low power warning? How can I test an antenna while getting low power warning?

RFxpert can measure a minimum source power of 0 dBm for a reasonable antenna. Reasonable means that the antenna is effective at radiating the available input power into free space, also known as being efficient. A Low Power error messages pop up at - 5 dBm of measured power. There is however, not a clear cutoff on when the low power measurements become inaccurately. This is mainly because we define the limit based on input power which is what the customer knows, but the RFxpert measures radiated power.

For example, if an antenna with less than 10% efficiency is tested with a 0 dBm source, the radiated power would be less than -10 dBm. RFxpert would very likely not be able to measure this antenna accurately even though minimum input power requirement is met. Whereas, an antenna with an efficiency of 50% fed with the same input power radiate -3dBm and can easily be characterized on RFxpert. So at a minimum we can measure an omnidirectional antenna that has an efficiency of 50% (-3 dB) from a 0 dBm source. If the efficiency or directivity drops then the minimum source power must be increased correspondingly.

The actual power that can be measured accurately changes versus frequency and also from system to system. This is why we use the more ambiguous term “reasonable” rather than a specific number. Additionally, it is often the case that the radiating properties (e.g., efficiency and directivity) of the antennas that are tested on RFxpert are not known.

Although 0 dBm is the minimum specification RFxpert can still perform accurately down to -5 dBm or -10 dBm at most frequencies. A low-power warning message will pop up when the maximum measured near-field is too close to the noise floor. First check phase pattern to judge whether the results are reasonable and add 3 dB to PRAD results. If in doubt, please send the file to EMSCAN.

How to check phase pattern? The phase will start to degrade first as RFxpert approaches minimum radiated power. The degradation will show up as ‘noise’ in the phase plot as is shown in the three images below. The center image is marginal and the right image is poor.

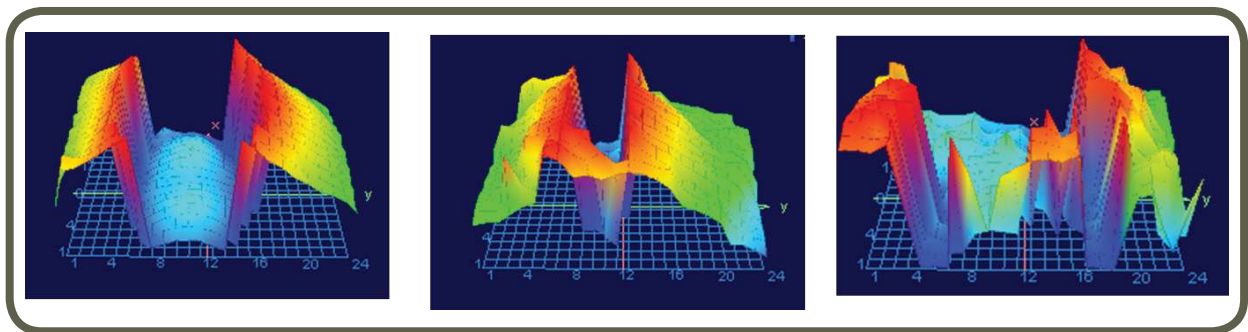

22. What is the resolution bandwidth of RFxpert?

The built in receiver has an IF bandwidth of 60 MHz. For modulated signals that are wider than 60 MHz there may be a slight offset in the reported far-field values. This offset can be determined by comparing a modulated signal to a CW signal for the same antenna or by comparing a chamber measurement to the RFxpert reported value.

23. What is the RFxpert TIS proxy?

Total Isotropic Sensitivity (TIS) is a measure of the average sensitivity of the receiver-antenna combination in a device under test. In practice, this average is taken from measurements at many angles of the minimum power needed to keep a reliable connection. A reliable connection is often defined as the power required to maintain a 2% Bit-Error Rate (BER). Measuring from many angles until the connection is no longer reliable takes a lot of test time.

The conducted power received by the receiver at each angle is a function of the receive gain pattern as well as the incident radiated power. The receiver is somewhat insensitive to how this conducted power is received and will typically show the same BER for the same conducted power levels. In this case the variability of sensitivity to different angles is strictly a function of the antenna pattern.

The antenna pattern is what RFxpert provides with its standard measurement capability. With knowledge of source power, a gain pattern can be calculated. This gain pattern can be combined with the receiver conducted sensitivity and averaged to calculate a TIS value. Since RFxpert can only measure over-the-air parameters of the antenna, the user needs to input the receiver conducted sensitivity.

The current version of RFxpert TIS calculations does averaging of the gain pattern before combining it with the receiver sensitivity. This average gain pattern is also known as efficiency, so TIS is simply the conducted receiver sensitivity plus the antenna efficiency.

This calculation is not a direct measure of the receive performance which is why EMSCAN calls it a TIS proxy. It can still be a good approximation when the conducted values of the device are known. It also is a very fast measurement.

This method may miss device's self-interference if the mechanism of interference is radiated from parts of the device and then received by the antenna. The more common conducted self-interference would still be identified with this method since it would show up in the receiver conducted sensitivity. This method also makes the assumption that the receive pattern of the device is the same as the transmit pattern. For devices with large frequency duplexing this assumption may not hold true.

Appendix

Comparing with a Golden Sample from Another Project

1. Open two project files

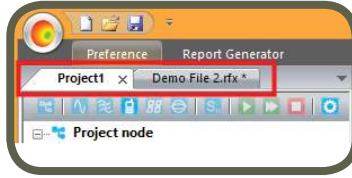

2. Go to the project file that has the scan node that you want to set as the golden sample. Right click on this node and select "Copy Node"

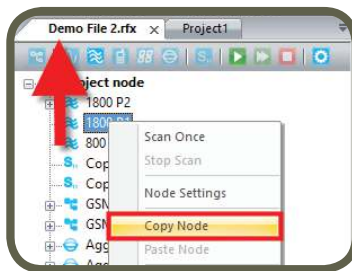

3. Go to the project file where you want to paste this scan node as golden sample. Left click to select the scan node you want to compare to the golden sample. Right click on this node and select "Paste Node"

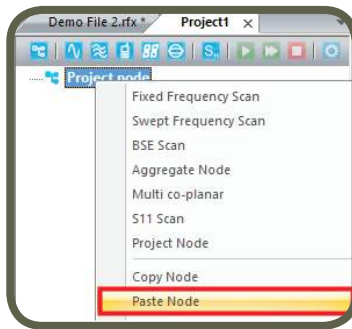

4. This automatically creates a golden sample node below the node you want to compare with it. It also automatically forces the state into the comparison mode and modifies the data list to show the comparisons

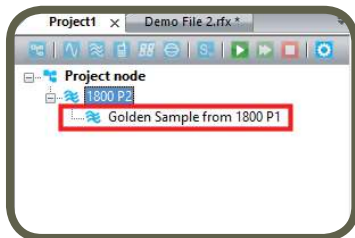

Freque...	ΔAnten...	ΔRadiat...	ΔGain (...)	ΔRealiz...	ΔPRAD ...	ΔEIRP (...)
1750.00	-4.09	-4.09	-0.82	-0.82	-0.73	-0.82
1760.00	-4.80	-4.80	-1.01	-1.02	-0.84	-1.02
1770.00	-5.51	-5.50	-1.05	-1.05	-0.88	-1.05
1780.00	-5.89	-5.88	-0.93	-0.93	-0.83	-0.93
1790.00	-6.85	-6.84	-0.91	-0.91	-0.85	-0.91
1800.00	-7.55	-7.54	-0.95	-0.95	-0.86	-0.95
1810.00	-8.13	-8.12	-1.04	-1.04	-0.85	-1.04
1820.00	-8.84	-8.84	-1.07	-1.07	-0.82	-1.07
1830.00	-7.15	-7.16	-0.89	-0.89	-0.60	-0.89
1840.00	-4.87	-4.88	-0.68	-0.68	-0.36	-0.68
1850.00	-1.73	-1.75	-0.49	-0.49	-0.11	-0.49
1860.00	1.30	1.27	-0.33	-0.32	0.08	-0.32
1870.00	4.29	4.26	-0.19	-0.19	0.26	-0.19
1880.00	6.84	6.81	-0.05	-0.04	0.42	-0.04

Creating Comparisons for Over the Air Measurements

This note covers the case for recommended use if one is comparing several samples at several frequencies (and possibly several power control levels)

1. Set the source for a given frequency, set up a [Fixed Frequency Scan \(page 50\)](#) node
2. Run a sequence of single measurements swapping out a different model for each individual measurements
3. Change the frequency, and repeat with a new Fixed Frequency Scan node
4. Now measure the golden sample or ["import" a golden sample \(page 66\)](#) for comparison purposes
5. To compare the outcomes, go to the [golden sample data list \(page 66\)](#) and,
 - Select the row that corresponds to a given frequency
 - Mark as a golden sample
 - Drag the created golden sample node and drop it on the scan node that has the corresponding results for many samples at that frequency

Connecting Power Meter and Network Analyzer

The output power of a network analyzer is not well controlled. Depending on the model you can have variations of 0.5 dB to 5 dB. If you also fail to take into account cable and connector losses another 1-3 dB of error can adversely affect furthermore your gain and efficiency measurements.

For accurate efficiency measurements, we strongly suggest that the network analyzer be calibrated when performing a Swept Frequency Scan. There are two ways to do this but the preferred method is to create a power meter profile. Direct use of a power meter can be employed in situations where the stability of the network analyzer is in question.

Below is the list of supported power meters. If your power meter is not listed, and want your power meter to be supported, please contact [EMSCAN](#) Technical Support.

HP	4418A	4419A				
Agilent	U2001A	U2001B	U2001H	U2000A	U2000B	U2000H
R&S	NRP	NRP2				

Note:

Keysight USB Power Sensors

If your Keysight Power Sensor can not be detected by the Keysight IO Libraries Suite under Windows 10, please follow these instructions below to fix the USBTMC driver issue:

1. Run the following command on a Command Prompt with Administrator privileges:

On 64-bit Windows:

```
dpinst /S /SE /SW /PATH "c:\Program Files\IVI Foundation\VISA\IVI USB Staging\b841aa80\Windows"
```

On 32-bit Windows:

```
dpinst /S /SE /SW /PATH "c:\Program Files\IVI Foundation\VISA\IVI USB Staging"
```

2. Unplug and replug the USB device.

U2000A 10 MHz - 18 GHz USB Power Sensor (Tested)

U2000B 10 MHz - 18 GHz USB Power Sensor

U2000H 10 MHz - 18 GHz USB Power Sensor

U2001A 10 MHz - 6 GHz USB Power Sensor

U2001B 10 MHz - 6 GHz USB Power Sensor

U2001H 10 MHz - 6 GHz USB Power Sensor (Tested)

U2002A 50 MHz - 24 GHz USB Power Sensor

U2002H 50 MHz - 24 GHz USB Power Sensor

U2004A 9 kHz - 6 GHz USB Power Sensor (Tested)

Power Meter Profile

Reading from a power meter, RFxpert software will store the actual network analyzer power at the end of the cable in a file. This power meter profile can be used to correct the radiated power readings as if the AUT was receiving a stable input power.

Creating a profile

To create a profile for a network analyzer you connect the output of port 1 to the power meter using your test cable. Both the network analyzer and power meter must be connected to the PC running RFxpert via the Keysight IO Libraries Suite. Connect the Network Analyzer first and the Power Meter next.. If the network analyzer and/or power meter were connected after the RFxpert application was opened, the RFxpert Application needs to be made aware of these new instruments. On the orange RF icon in the START Menu, left click and select Refresh Instrument or click on the Refresh icon to the bottom right of the RFxpert application window.

In the ‘Settings’ window of the swept frequency node there is a ‘Power Meter Settings’ tab. Select the Use Stored Profile button and click on Create/Edit to create a new power profile or edit a power profile that has been loaded up, click on Load to bring up an existing power profile, or click on Save As to save an edited power profile.

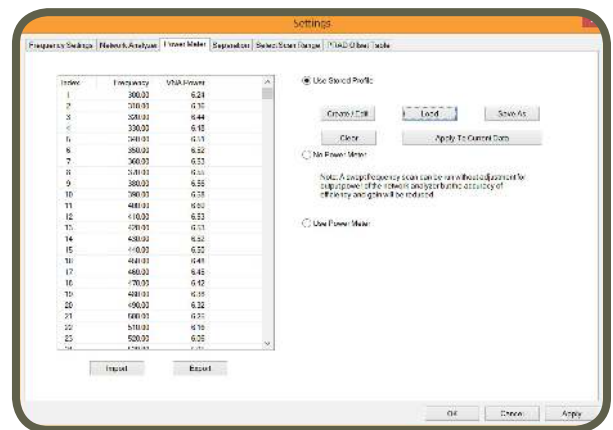
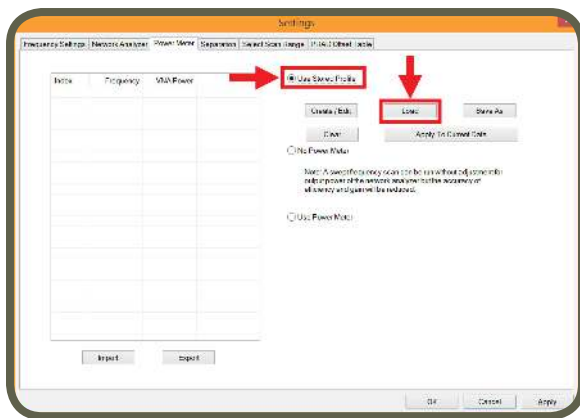

To create a profile automatically, simply enter the start, stop frequency and number of points. The output power must be within the limits of the network analyzer but typically should be the maximum allowed value. When you click the ‘Create Profile’ button you see the list being populated. If these values seem reasonable, click the OK button. You can use the profile immediately or save it by clicking on the Save As button.

You can either set a range for a single test or you can create a list that will characterize the setup over the entire operating band (e.g., 300 MHz to 6 GHz). Note that the file will only apply to the particular network analyzer and cable combination and that the power could still drift over time.

Editing a profile

*This feature is for advanced users. Improper settings can severely affect the accuracy of RFxpert. However, there is no danger of permanently affecting the results. The results will only be inaccurate as long as the modified profile file is being used.

This can be used to further increase the accuracy of RFxpert by not only calibrating for output power but also allowing the user to custom calibrate results for their particular antenna. For example, if the user is testing a particular model of antenna and they find there is a systematic 1.2 dB offset in gain values as compared to a chamber test they can adjust the power profile to force the results to match.

Doing this will change the predicted results and EMSCAN can no longer ensure the accuracy but for advanced users this can be an effective way to exactly match RFxpert results to chamber results. The goal being for future testing of the same antenna model the results can now be compared directly to chamber measurements.

Using a profile

If the user has already created a profile and has stored this on their computer then they can easily reuse this profile for future tests. To do this they simply go to the 'Power Meter Settings' tab of the settings window and click on Load to search for the desired stored profile.

If the stored frequencies cover the range that is currently being measured, the power values are automatically adjusted with a linear interpolation of the stored output power values.

Caution:

- Do not overload the power sensor maximum rating. Otherwise power sensor will be damaged
- Achieve input power to DUT between 0 – 33 dB for reliable data

Power Metering in Real-Time

- First connect the PC to the Power Meter. If you are using a power meter that can use a USB connection then simply connect the power meter to the PC and detect it with the Agilent IO user interface. For power meters that use GPIB interface you can use the USB-GPIB adapter. If this is already being used for the Network Analyzer you can simply use a GPIB jumper cord to connect the two instruments. This is shown in the image below



Network Analyzer and Power Meter Setup Showing Power and USB Cables

- Ensure that the network analyzer is properly connected to the PC and detected using the Agilent IO interface.
- Plug the network analyzer and power meter power cords
- Necessary to use an amplifier at the output of the Network analyzer if a minimum of 0dBm cannot be maintained at the antenna feedpoint. If the antenna is sensitive to this setup then matching 3-6dB attenuators can be placed after the splitter in the path to the antenna and the power meter.

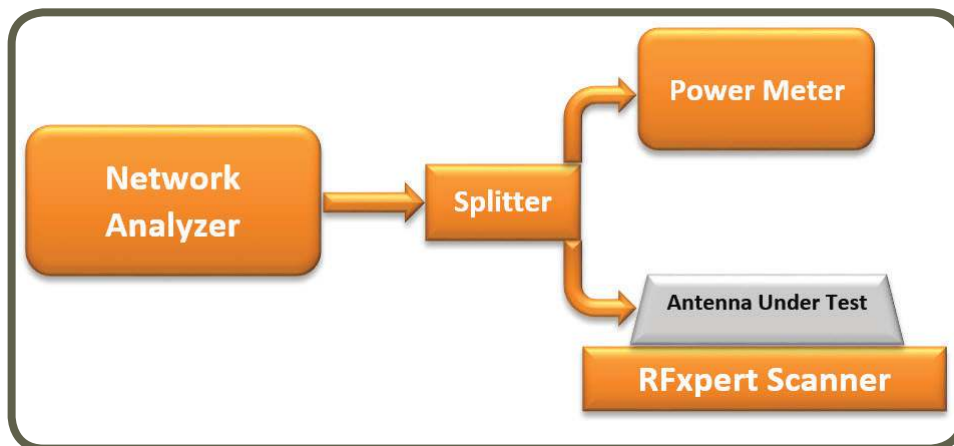

Power Meter Sensor and Power Splitter Setup

Working with Unsupported Power Meters

It is possible to create a profile from an unsupported power meter. In this case, manual measurements can be done for each frequency set in the Swept Frequency Settings and entered manually through the Create/Edit function by using the Manual menu. First click on Create/Edit. Then in the Manual section, enter each frequency and power value one by one by clicking Add. When finished click OK. You end up back to Settings window and you can save as this profile.

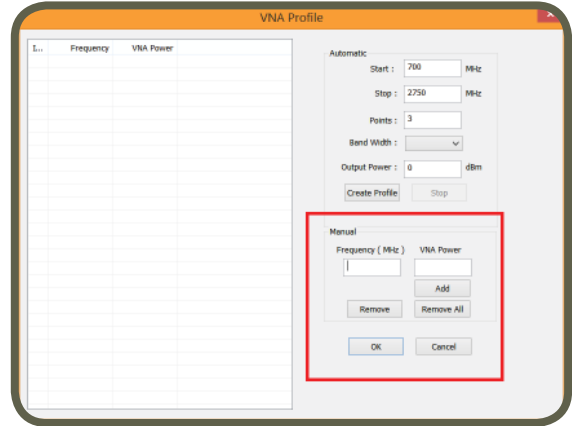

GPIB Instrument Connection (HP 8714ES/ED or Agilent 8960)

When the instrument is connected via GPIB, follow below steps:

- Right click IO icon on bottom right corner of the Windows and select Agilent Connection Expert



- Keysight Connection Expert window will be displayed. Click on Settings, then select Keysight 488 options and check the box Enable Keysight GPIB Cards for 488 Programs.

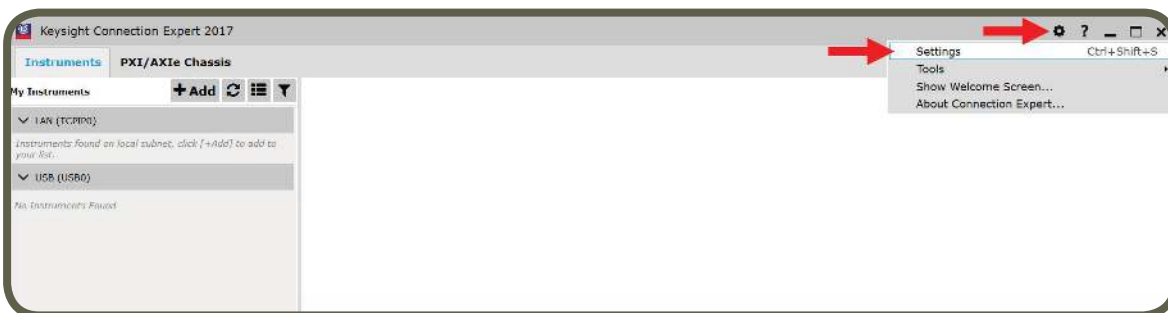

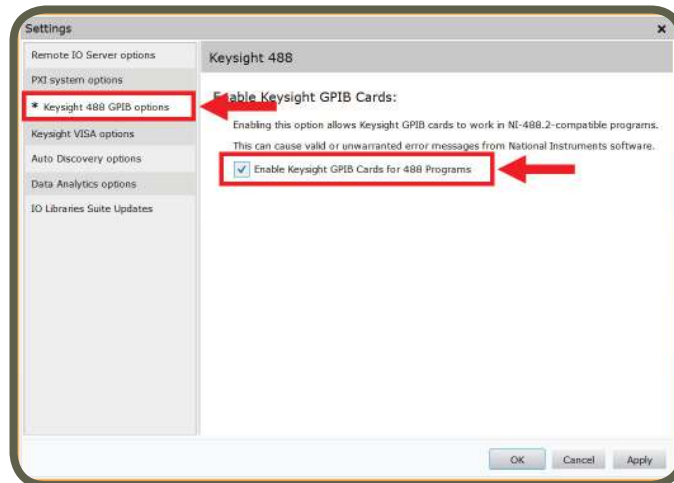

- Reboot your PC

Total Radiated Power (TRP) Measurements with Phantom Head + Hand Test Kit

Available only for RFX2 models

Total Radiated Power (TRP) measurements using a phantom head and hand are an important performance requirement for mobile device manufacturers and wireless service providers. Therefore, CTIA has developed a Test Plan for Mobile Station Over the Air (OTA) Performance. EMSCAN collaborated with a CTIA listed phantom fixture manufacturer, IndexSAR, to provide an OTA Performance bench top test fixture with phantom head+hand. The bench top test fixture can be used for 'talk mode' testing or as a device fixture for free space testing. The RFX2 scanner used in this test fixture can perform fast accurate measurements with excellent correlation to a full compliant OTA test system.

Setup

Position the DUT in the hand and next to the head according to the CTIA test plan . Place the DUT and the phantoms in front of the RFX2 scanner as shown below. A measurement from each hemisphere needs to be done to get a complete spherical pattern and a full TRP result. The step by step guide to get proper results is given below.

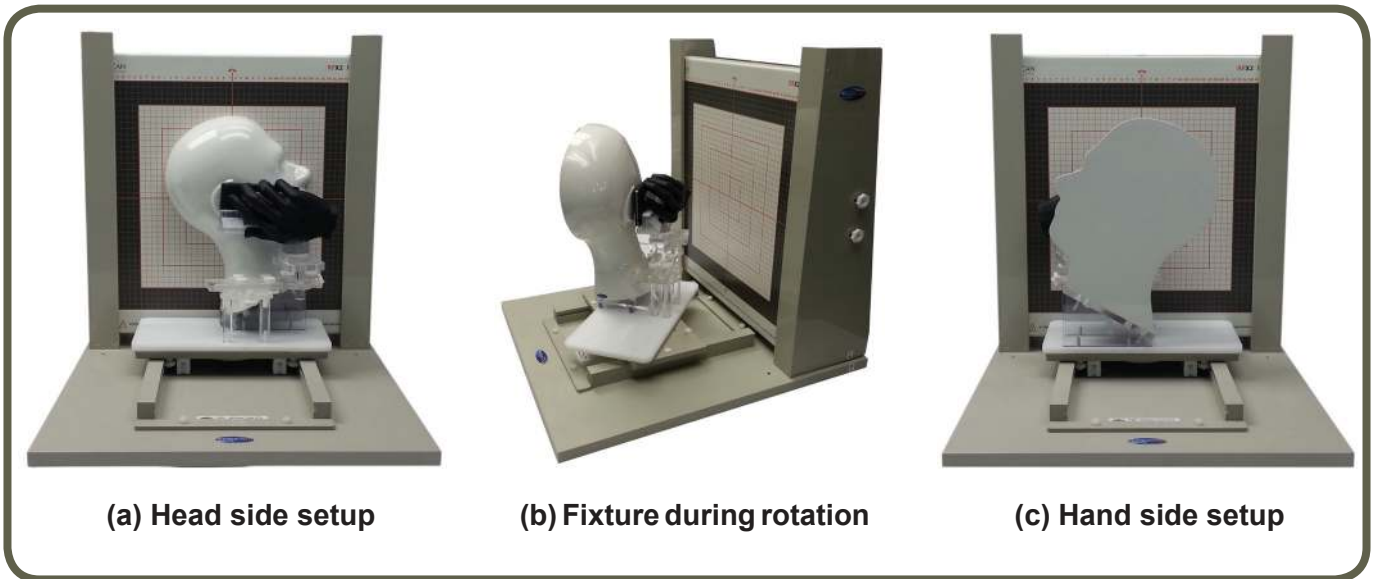

1. Place the head side next to the RFX2 scanner as shown in Figure (a). Be sure the head is right next to the scanner lid surface.
2. Measure the separation between the embedded antenna and the surface of the scanner. Enter the 85 mm value into the RFxpert software under the separation tab of the settings.

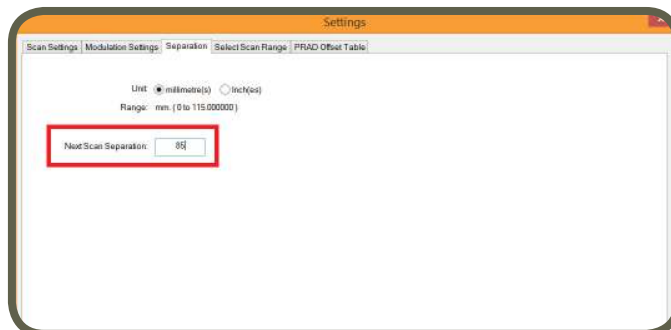

- Apply the special adjustment factor to convert from free space measurement to phantom measurements. This is done in the PRAD Offset Table tab of the settings. When using the phantom kit the RFxpert reports values 3.60dB too high in the low band so a -3.60dB offset must be applied to the software. The offset in the high band is +4.00dB. Both ranges can be set up in one table as shown below. If there is any other user applied offset for specific chamber calibration this needs to be added to the results shown in the table.

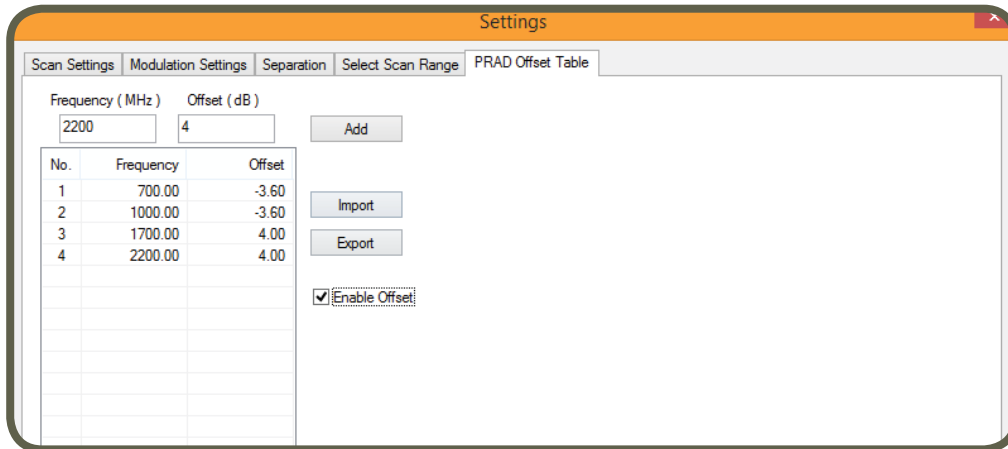

- Using the BSE scan for a series of measurements, run a scan of the head side. General setup for measurement of mobile UE is described on [page 56](#) of this manual.
- Flip the head and hand fixture as shown in Figure (b).
- Create a new scan node to measure the second side and repeat steps 2-4. The separation to the phone may be different on the hand side. Use the same PRAD offset values.
- Use the Aggregate node ability in the software to combine the head side measurement with the hand side measurements. The aggregate node will now show the TRP value for the UE in the presence of the phantom head and hand.

Error Messages

If you receive other error messages please contact [EMSCAN](#) Technical Support

Error Messages	Possible Causes	Action
Error 0001	Another RFxpert application is running	Only one RFxpert application is allowed.
Error 0002	Project file is not compatible.	Import files with .lbj file format
Error 0003	Writing configuration zip file failed.	Check folder properties and make sure it is not Read-Only
Error 0004	Failed to connect RFxpert scanner.	Contact EMSCAN Technical Support.
Error 0005	Failed to disconnect RFxpert scanner.	Contact EMSCAN Technical Support.
Error 1010	Failed to read HeaderFile.txt	Contact EMSCAN Technical Support.
Error 1011	Can not open correction head file.	Contact EMSCAN Technical Support.
Error 1012	Incorrect data format in configuration source file.	Contact EMSCAN Technical Support.
Error 1013	Can not open correction file.	Contact EMSCAN Technical Support.
Error 1014	Can not create configuration file.	Contact EMSCAN Technical Support.
Error 1015	Cannot open	Contact EMSCAN Technical Support.
Error 1016	Failed to read antenna measurement information file.	Contact EMSCAN Technical Support.
Error 1017	Can not open band information file.	Contact EMSCAN Technical Support.
Error 1018	Can not find PathPhase correction file. Please contact EMSCAN.	Contact EMSCAN Technical Support.
Error 1019	Failed to open PathPhase loss correction file.	Contact EMSCAN Technical Support.
Error 1020	Can not find file	Contact EMSCAN Technical Support.
Error 1021	Failed to open file	Contact EMSCAN Technical Support.
Error 1022	Can not find probe correction file. Please contact EMSCAN.	Contact EMSCAN Technical Support.
Error 1023	Failed to open probe correction file.	Contact EMSCAN Technical Support.
Error 1024	Cannot delete existing *.xls file(s). The file(s) is/are in use by another program You must close the file(s) before proceeding.	The target file is locked. Either it is open or set as read only

Error Messages	Possible Causes	Action
Error 1025	Cannot find configuration file.	The configuration file has become corrupted or deleted. Please reinstall RFxpert application
Error 1026	Failed to read reference antenna information file.	Contact EMSCAN Technical Support.
Error 1027	Cannot serialize configuration file	The configuration file is wrong. Please reinstall RFxpert software and try again. If the problem persists, contact EMSCAN technical support.
Error 1028	Failed to store configuration file.	Contact EMSCAN Technical Support.
Error 1029	Invalid schema	Contact EMSCAN Technical Support.
Error 1030	Invalid class	Contact EMSCAN Technical Support.
Error 1031	Invalid index.	Contact EMSCAN Technical Support.
Error 1032	Invalid file	Contact EMSCAN Technical Support.
Error 1033	Unrecognized data format.	Contact EMSCAN Technical Support.
Error 1034	An OpenGL error occurred:	There is a potential problem with the windows OpenGL installation. Contact EMSCAN Technical Support.
Error 1035	You need to select one type of data to export or click Cancel	If you don't select the type of data to be exported, this error message will appear. Please select the type of data to export to excel.
Error 1036	Failed to set probe or get reference amplitude.	Contact EMSCAN Technical Support.
Error 1037	USB Error: I/O pending	Check the USB connection. If the error message still appears, contact EMSCAN Technical Support.
Error 1038	No data was exported.	Trying to export an empty data list will cause this error.
Error 1039	Frequency value exists in frequency list.	The frequency value entered is already in the list.
Error 1040	Start frequency should be smaller than stop frequency.	Enter a smaller value in the start frequency than the stop frequency.

Error Messages	Possible Causes	Action
Error 1041	ChoosePixelFormat failed.	There is a potential problem with the windows OpenGL installation. Contact EMSCAN Technical Support.
Error 1042	SetPixelFormat failed (no OpenGL compatible video mode)	There is a potential problem with the windows OpenGL installation. Contact EMSCAN Technical Support.
Error 1043	Frequency value is out of range.	Please enter a frequency value between 300 and 6000. Between each band there are few gaps, make sure not to select between the frequency band gaps. Contact EMSCAN Technical Support.
Error 1044	The DialogBar is not docked.	Contact EMSCAN Technical Support.
Error 1045	DialogBar is docked alone.	Contact EMSCAN Technical Support.
Error 1046	Max should be bigger than Min for amplitude.	Enter a greater value in the Max amplitude than the Min amplitude.
Error 1047	File size exceeds limits.	File is too large to save. Please move some nodes into a new project and try again
Error 1048	Missing RFxpertDLL.dll file.	The installation has become corrupted. Please reinstall the application
Error 1049	Cannot connect USB device. Please check if the USB device is installed properly.	Check the USB connection and whether the USB driver is installed properly. If the problem persists contact EMSCAN technical support.
Error 1050	Cannot find DLL file for USB device. Make sure DLL file is installed properly.	Make sure DLL file for USB device is installed properly
Error 1051	Get DLL Procedure - Address Error.	Contact EMSCAN technical support.
Error 1052	USB packet error.	Contact EMSCAN technical support.
Error 1053	Running RFxpert for the first time or cannot find configuration file. Do you want to select configuration file from your computer?	For some RFxpert systems you must manually select the configuration file from the CD when first installing the application.
Error 1054	Read scanner flash memory data stream size exceeded limit.Please contact EMSCAN.	Contact EMSCAN Technical Support.
Error 1055	Registry Error	Contact EMSCAN technical support.

Error Messages	Possible Causes	Action
Error 1056	Measured Frequency is out of range. Try again.	Please enter a frequency value between 300 and 6000.
Error 1057	Read data time out. Try again or restart RFxpert hardware.	If scanner is unplugged during a scan, this error message will appear. Please check the connection, reboot the system and try again.
Error 1058	Get hardware correction data problem or release hardware correction data problem. Please contact EMSCAN.	Contact EMSCAN technical support.
Error 1059	Get calibration data problem. Please contact EMSCAN.	Contact EMSCAN technical support.
Error 1060	Get phase shift value problem. Please contact EMSCAN.	Contact EMSCAN technical support.
Error 1061	Get configuration data problem. Please contact EMSCAN.	Contact EMSCAN technical support.
Error 1062	Get phase loss data problem. Please contact EMSCAN.	Contact EMSCAN technical support.
Error 1063	Get probe factor problem. Please contact EMSCAN.	Contact EMSCAN technical support.
Error 1064	Get phase calculation data problem. Please contact EMSCAN.	Contact EMSCAN technical support.
Error 1065	No device detected. Try again.	Check RFxpert connections and try again.
Error 1066	Set scan frequency or frequency is out of range.	Enter a frequency value between 300 and 6000.
Error 1067	There is no response in TDMA mode	Check TDMA source signal
Error 1068	Failed to set frequency.	Contact EMSCAN .
Error 1069	Failed to get reference antenna index.	Contact EMSCAN .
Error 1070	Scan failed.	Check RFxpert and other instruments connections. If the problem persists please contact EMSCAN technical support.
Error 1071	Failed to load RFxpertDLL.DLL.	Check if RFxpert DLL.DLL exists in the application folder (C:\Program Files\EMSCAN Corporation\RFxpert)
Error 1072	Cannot create VNA profile.	The application cannot write to the destination folder. Make sure the folder properties are set to allow writing
Error 1073	Cannot open VNA Profile.	The application cannot write to the destination folder. Make sure the folder properties are set to allow writing

Error Messages	Possible Causes	Action
Error 1074	Cannot read - write VNA profile.	The application cannot write to the destination folder. Make sure the folder properties are set to allow writing
Error 1075	VNA Profile list is empty or frequency points and profile list item count are not equal.	Set the list of frequencies again and retry.
Error 1076	Cannot find VNA Profile.	The application cannot write to the destination folder. Make sure the folder properties are set to allow writing
Error 1077	Failed to load VNA profile.	Contact EMSCAN technical support.
Error 1078	Frequency is out of VNA profile frequency range.	Set the scan frequency within the VNA profile frequency range
Error 1079	Connection with VNA failed	Check VNA cable connection
Error 1080	VNA profile file name is empty.	Choose a profile name and retry
Error 1081	Unrecognizable GPIB equipment.	GPIB equipment is not currently supported. Contact EMSCAN technical support.
Error 1082	Traffic channel exceed range limit	Make sure the traffic channel does not exceed the range limit that is displayed on the dialog box
Error 1083	Broadcast channel exceed range limit	Make sure the broadcast channel does not exceed the range limit that is displayed on the dialog box
Error 1084	PCL list is empty	Enter PCL level in the list
Error 1085	Incorrect GPIB address	Connection with Network Analyzer can't be established. Please check GPIB address.
Error 1086	Network Analyzer scan frequency list is empty.	Make sure to add linear sweep start and stop frequencies in the settings of Swept Frequency or S ₁₁ Scan.
Error 1087	Multiple Sample number should be bigger than 0.	Contact EMSCAN Technical Support.
Error 1088	Please enter valid Multiple Sample number.	Contact EMSCAN Technical Support.
Error 1089	Down Link channel list is empty.	Contact EMSCAN Technical Support.
Error 1090	UE target power list is empty.	Contact EMSCAN Technical Support.
Error 1091	Traffic channel is empty.	Contact EMSCAN Technical Support.

Error Messages	Possible Causes	Action
Error 1092	Out of Output power range.Please check Network Analyzer user manual.	Contact EMSCAN Technical Support.
Error 1093	Please select NA mode.	Contact EMSCAN Technical Support.
Error 1094	Cannot find or this is not valid file name.	Contact EMSCAN Technical Support.
Error 1095	Preset power meter failed.	Contact EMSCAN Technical Support.
Error 1096	Out of separation range	Contact EMSCAN Technical Support.
Error 1097	No matched separation value in configuration.Please contact EMSCAN.	Contact EMSCAN Technical Support.
Error 1098	Please enter a valid value.	Contact EMSCAN Technical Support.
Error 1099	Can not delete file	Contact EMSCAN Technical Support.
Error 1100	Node item cannot be dropped onto itself	A scan node cannot be dropped onto itself to make comparison
Error 1101	This node cannot be dropped onto its parent node	A sub node cannot be dropped onto its parent/main node
Error 1102	This node cannot be dropped onto one of its children node	A main node cannot be dropped onto one of its children/sub node
Error 1103	This node can't be dropped onto this node	The node that you are trying to compare must have same settings and be the same scan type
Error 1104	The following items must exactly match: 1. Number of scans 2. Scan frequency 3. Signal channels and PCL levels for BSE node.	The two scans placed into an aggregate node must have the same frequency points and/or power levels
Error 1105	Frequency order should be in ascending order	Contact EMSCAN Technical Support.
Error 1106	Selected bandwidth is not available	Refer to VNA settings
Error 1107	Please specify folder and file name	Contact EMSCAN Technical Support.
Error 1108	Cannot get band information. Please contact EMSCAN.	Contact EMSCAN technical support.
Error 1109	Frequency X is out of license range. It should be within Y and Z MHz	Make sure the frequency is in your license range.
Error 2000	GPIB Device Error. Please check the Network Analyzer connection	Connection with Network Analyzer can't be established. Please check GPIB address.
Error 2001	VNA write error	Please check the connection with Network Analyzer and try again.

Error Messages	Possible Causes	Action
Error 2002	GPIB Read Error	Please check the connection with the external instrument and try again.
Error 2003	Network Analyzer Read Error	You'll receive this message when you run a Swept Frequency or S_{11} scan with no NA connected or the device is set to "System Controller". Ensure all remote devices are set as "talker/listener".
Error 2004	Power Meter Read Error	You'll receive this message when you run a Swept Frequency or S_{11} scan with no Power Meter connected or the device is set to "System Controller". Ensure all remote devices are set as "talker/listener".
Error 2005	Error taking VNA device offline.	Please check the connection with the external instrument and restart the application. Restart the Agilent IO if the problem persists
Error 2006	Error taking VNA interface offline.	Please check the connection with the external instrument and restart the application. Restart the Agilent IO if the problem persists
Error 2007	Error taking PM device offline.	Please check the connection with the external instrument and restart the application. Restart the Agilent IO if the problem persists
Error 2008	Error taking PM interface offline.	Please check the connection with the external instrument and restart the application. Restart the Agilent IO if the problem persists
Error 2009	GPIB Device Error. Please check the connection and setting of Power Meter	If running a Swept Frequency Scan or S_{11} with no GPIB controller connected, this error message will appear. Please try the following suggestions: 1) Check cable connection 2) Check if the driver is properly installed. 3) Check if GPIB card is properly installed

Error Messages	Possible Causes	Action
Error 2010	Failed to read output from Power Meter GPIB Device command. Please check the connection and setting of Power Meter.	You'll receive this message when you run a Swept Frequency or S_{11} scan with no Power Meter connected or the device is set to "System Controller". Ensure all remote devices are set as "talker/listener".
Error 2011	Power meter write error	You'll receive this message when you run a Swept Frequency or S_{11} scan with no Power Meter connected or the device is set to "System Controller". Ensure all remote devices are set as "talker/listener".
Error 2012	VNA GPIB address and Power Meter GPIB address are the same	The addresses should not be the same
Error 2013	Cannot connect Base Station Emulator	1) Check cable connection 2) Check if the driver is properly installed
Error 2014	Incorrect channel	Select a transmit channel that is in the acceptable range.
Error 2015	No related path loss data of such frequency	Contact EMSCAN technical support.
Error 2016	Call disconnected; No response to page	Cell phone didn't response to the BSE call.
Error 2017	Base Station Emulator firmware is not supported	Contact EMSCAN technical support.
Error 3001	Could not initialize the GPIB Device. Please check the connection of	1) Check cable connection 2) Check if the driver is properly installed 3) Check if GPIB card is properly installed
Error 3003	Failed to execute GPIB command:	Contact EMSCAN technical support.
Error 4000	Invalid channel number	Enter a correct channel range
Error 4001	Please enter valid channel number	Enter a channel number inside the channel range
Error 4002	Selected channel exists in the list	Check the list, and make sure to enter a channel that is not on the list
Error 4004	Please enter valid PCL	Ensure there is at least one PCL level added in the list
Error 4005	PCL Value exists	Check the list, and make sure to enter a PCL that is not on the list

Error Messages	Possible Causes	Action
Error 4006	Please enter a valid Power In value	Power in must be set in dBm
Error 4007	Please enter a valid return loss value. Return loss value should be less than 0	Return loss should be a negative value entered in dB
Error 4008	Please enter a valid Timeout value. Timeout value should not be smaller than 0.	Timeout is a time in msec greater than 0.
Error 4009	Please enter a valid Threshold value. Threshold value should not be smaller than -5.	Threshold is power level in dBm and it should not be smaller than -5.
Error 4010	Please enter a valid Holdoff value. Holdoff value should not be smaller than 0.	Holdoff is a time in use greater than 0.
Error 4011	Cannot change the settings of the node	If a node which is placed under an aggregate node cannot have the settings changed. Remove the node from the aggregate node and try again
Error 5000	This is invalid license file	Contact EMSCAN technical support.
Error 5001	Cannot create file:	The application cannot write to the destination folder. Make sure the folder properties are set to allow writing
Error 5002	Cannot read file :	The application cannot write to the destination folder. Make sure the folder properties are set to allow writing
Error 5003	License Error. Cannot encrypt data.	Contact EMSCAN Technical Support.
Error 5004	License Error. Cannot decrypt data. Please contact EMSCAN.	Contact EMSCAN Technical Support.
Error 5005	License has expired. For more information please contact EMSCAN.	Contact EMSCAN Technical Support.
Error 5006	Failed to load license file	Contact EMSCAN Technical Support.
Error 5007	Failed to decompress the configuration file.	Contact EMSCAN Technical Support.
Error 5008	Pulling configuration file from firmware failed.	Contact EMSCAN Technical Support.
Error 5009	License is not assigned to this unit. Please contact EMSCAN.	Contact EMSCAN Technical Support.
Error 5010	Please contact EMSCAN to get the correct license.	Contact EMSCAN Technical Support.
Error 5011	Uploading config file to flash memory failed.	Restart RFxpert hardware and try again
Error 5012	Loading configuration file failed.	Restart RFxpert hardware and try again
Error 5013	You already updated this license.	Contact EMSCAN Technical Support.

Error Messages	Possible Causes	Action
Error 5014	Unable to de-archive 7z file.	Contact EMSCAN Technical Support.
Error 5015	Error 5015:\n\n Failed to update license Please Contact EMSCAN.	Contact EMSCAN Technical Support.
Warning 027	RFxpert Project Files cannot be opened without a configuration file.	Please connect to hardware to download the configuration file.
Warning 028	No configuration file present.	Please connect to hardware to download the configuration file.”

Glossary (Summary of Far-Field Values)

- **Radiation Pattern:** Far field radiation intensity versus angle with peak as directivity (dBi)

$$U = P \cdot r^2$$

- **Prad (Power Radiated):** The total radiated power in one hemisphere (dBm)
- **TRP (Total Radiated Power):** The total radiated power in two hemispheres (dBm)

$$TRP = \iint U(\theta, \varphi) \sin \theta \, d\theta \, d\varphi$$

- **Directivity:** How well the antenna intensifies radiation intensity in peak direction (dBi)

$$D = 4\pi \left(\frac{U_{max}}{TRP} \right)$$

- **Efficiency:** Antenna efficiency is ratio of input power to radiated power(%)

$$P_{accepted} = P_{delivered} (1 - S_{11}^2)$$

$$E_{radiated} = \left(\frac{TRP}{P_{accepted}} \right) \quad E_{antenna} = \left(\frac{TRP}{P_{delivered}} \right)$$

- **Gain:** This is the peak antenna gain using accepted power as input (dBi)

$$G = E \cdot D = 4\pi \cdot U_{max} / P_{accepted}$$

$$G_{realized} = E \cdot D = 4\pi \cdot U_{max} / P_{delivered}$$

- **EIRP (Effective Isotropic Radiated Power):** Equal to the TRP plus directivity (dBm)

$$EIRP = TRP \cdot D = \iint U_{max} \sin \theta \, d\theta \, d\varphi = 4\pi \cdot U_{max}$$

- **Envelope correlation (ρ_e):** is a measure of how closely two separate radiation patterns match.

$$\rho_e = \frac{|\iint_{4\pi} d\Omega U_1(\theta, \varphi)^* \cdot U_2(\theta, \varphi)|^2}{\iint_{4\pi} d\Omega |U_1(\theta, \varphi)|^2 \iint_{4\pi} d\Omega |U_2(\theta, \varphi)|^2}$$

- **Correlation:** is the square root of envelope correlation

$$\rho = \sqrt{\rho_e}$$

Glossary (CTIA Parameters)

1) Tot. Rad. Pwr. (dBm)	2.01
2) Peak EIRP(dBm)	9.19
3) Directivity (dBi)	6.7
4) Efficiency (dB)	N/A
5) Efficiency (%)	N/A
6) Gain (dBi)	N/A
7) NHPRP $\pm\pi/4$ (dBm)	-1.#J
8) NHPRP $\pm\pi / 6$ (dBm)	-1.#J
9) NHPRP $\pm\pi / 8$ (dBm)	-1.#J
10) Upper Hem. PRP (dBm)	1.69
11) Lower Hem. PRP (dBm)	-9.48
12) NHPRP4 / TRP Ratio (dB)	-1.#J
13) NHPRP 4 / TRP Ratio(%)	-1.#J
14) Near Horz.TRP for $\pm\pi / 4$ (dBm)	-1.#J
15) NHPRP6 / TRP Ratio (dB)	-1.#J
16) NHPRP 6 / TRP Ratio(%)	-1.#J
17) Near Horz.TRP for $\pm\pi / 6$ (dBm)	-1.#J
18) NHPRP8 / TRP Ratio (dB)	-1.#J
19) NHPRP 8 / TRP Ratio(%)	-1.#J
20) Near Horz.TRP for $\pm\pi / 8$ (dBm)	-1.#J
21) UHPRP / TRP Ratio (dB)	-0.32
22) UHPRP / TRP Ratio(%)	92.91
23) Upper Hem.Total Radiated Pwr (dBm)	4.69
24) LHPRP / TRP Ratio (dB)	-11.5
25) LHPRP / TRP Ratio(%)	7.09
26) Lower Hem. Total Radiated Pwr(dBm)	-6.48
32) Boresight Phi (°)	180
33) Boresight Th. (°)	0

1. Tot. Rad. Pwr. (dBm) = Total Radiated Power

$$TRP = \frac{\sum_{\theta} \sum_{\varphi} (U_{\theta}(\theta_i, \varphi_j) + U_{\varphi}(\theta_i, \varphi_j)) W(\theta_i)}{4\pi}$$

2. Peak EIRP (dBm) = Peak value of the Radiated Power pattern

$$\text{Max}(U_{\theta}(\theta_i, \varphi_j) + U_{\varphi}(\theta_i, \varphi_j))$$

3. Directivity (dBi)

$$D = \frac{EIRP}{\sum_{\theta} \sum_{\varphi} (U_{\theta}(\theta_i, \varphi_j) + U_{\varphi}(\theta_i, \varphi_j)) W(\theta_i)}$$

4. Efficiency (dB): Antenna efficiency is ratio of input power to radiated power(%)

$$P_{accepted} = P_{delivered} (1 - S_{11}^2)$$

$$E_{radiated} = \left(\frac{TRP}{P_{accepted}} \right) \quad E_{antenna} = \left(\frac{TRP}{P_{delivered}} \right)$$

5. Efficiency (%): Antenna Efficiency in percent

6. Gain (dBi): This is the peak antenna gain using accepted power as input (dBi)

$$G = E \cdot D = 4\pi \cdot U_{max} / P_{accepted}$$

$$G_{realized} = E \cdot D = 4\pi \cdot U_{max} / P_{delivered}$$

7. NHPRP $\pm\pi/4$ (dBm) = Near-Horizon Partial Radiated Power from +45° to -45°

$$\frac{(\sum_{45 < \theta < 135} \sum_{\varphi} (U_{\theta}(\theta_i, \varphi_j) + U_{\varphi}(\theta_i, \varphi_j)) W(\theta_i) + \frac{1}{2} \sum_{\theta=45,135} \sum_{\varphi} (U_{\theta}(\theta_i, \varphi_j) + U_{\varphi}(\theta_i, \varphi_j)) W(\theta_i))}{4\pi}$$

8. NHPRP $\pm\pi/6$ (dBm) = Near-Horizon Partial Radiated Power from +30° to -30°

$$\frac{(\sum_{60 < \theta < 120} \sum_{\varphi} (U_{\theta}(\theta_i, \varphi_j) + U_{\varphi}(\theta_i, \varphi_j)) W(\theta_i) + \frac{1}{6} \sum_{\theta=59.4,120.6} \sum_{\varphi} (U_{\theta}(\theta_i, \varphi_j) + U_{\varphi}(\theta_i, \varphi_j)) W(\theta_i))}{4\pi}$$

9. NHPRP $\pm\pi/8$ (dBm) = = Near-Horizon Partial Radiated Power from +22.5° to -22.5°

$$\frac{(\sum_{67.5 < \theta < 112.5} \sum_{\varphi} (U_{\theta}(\theta_i, \varphi_j) + U_{\varphi}(\theta_i, \varphi_j)) W(\theta_i))}{4\pi}$$

10. Upper Hem. PRP (dBm) = Upper hemisphere partial radiated power (Prad from top scan)

$$\frac{(\sum_{\theta < 90} \sum_{\varphi} (U_{\theta}(\theta_i, \varphi_j) + U_{\varphi}(\theta_i, \varphi_j)) W(\theta_i) + \frac{1}{2} \sum_{\theta=90} \sum_{\varphi} (U_{\theta}(\theta_i, \varphi_j) + U_{\varphi}(\theta_i, \varphi_j)) W(\theta_i))}{4\pi}$$

11. Lower Hem. PRP (dBm) = Lower hemisphere partial radiated power (Prad from bottom scan)

$$\frac{(\sum_{\theta > 90} \sum_{\varphi} (U_{\theta}(\theta_i, \varphi_j) + U_{\varphi}(\theta_i, \varphi_j)) W(\theta_i) + \frac{1}{2} \sum_{\theta=90} \sum_{\varphi} (U_{\theta}(\theta_i, \varphi_j) + U_{\varphi}(\theta_i, \varphi_j)) W(\theta_i))}{4\pi}$$

12. NHPRP4 / TRP Ratio (dB) $\text{NHPRP}_{\pm\pi/4} \text{ (dBm)} - \text{TRP (dBm)}$

13. NHPRP4 / TRP Ratio (%) $\text{NHPRP}_{\pm\pi/4} \text{ (mW)} / \text{TRP (mW)}$

14. Near Horz. TRP for $\pm\pi/4$ (dBm) = TRP if $\text{NHPRP}_{\pm\pi/4}$ were in all directions

$$10\text{Log} \left[\text{NHPRP}_{\pm\pi/4} \text{ (linear)} \times \frac{4\pi}{\left(\sum_{45<\theta<135} \sum_{\varphi} W(\theta_i) + \frac{1}{2} \sum_{\theta=45,135} \sum_{\varphi} W(\theta_i) \right)} \right]$$

15. NHPRP6 / TRP Ratio (dB) $\text{NHPRP}_6 \text{ (dBm)} - \text{TRP (dBm)}$

16. NHPRP6 / TRP Ratio (%) $\text{NHPRP}_6 \text{ (linear)} / \text{TRP (linear)}$

17. Near Horz. TRP for $\pm\pi/6$ (dBm) = TRP if $\text{NHPRP}_{\pm\pi/6}$ were in all directions

$$10\text{Log} \left[\text{NHPRP}_{\pm\pi/6} \text{ (linear)} \times \frac{4\pi}{\left(\sum_{60<\theta<120} \sum_{\varphi} W(\theta_i) + \frac{1}{6} \sum_{\theta=59.4,120.6} \sum_{\varphi} W(\theta_i) \right)} \right]$$

18. NHPRP8 / TRP Ratio (dB) $\text{NHPRP}_8 \text{ (dBm)} - \text{TRP (dBm)}$

19. NHPRP8 / TRP Ratio (%) $\text{NHPRP}_8 \text{ (linear)} / \text{TRP (linear)}$

20. Near Horz. TRP for $\pm\pi/8$ (dBm) = TRP if $\text{NHPRP}_{\pm\pi/8}$ were in all directions

$$10\text{Log} \left[\text{NHPRP}_{\pm\pi/8} \text{ (linear)} \times \frac{4\pi}{\left(\sum_{67.5<\theta<112.5} \sum_{\varphi} W(\theta_i) \right)} \right]$$

21. UHPRP / TRP Ratio (dB) $\text{UHPRP (linear)} / \text{TRP (linear)}$

22. UHPRP / TRP Ratio (%) $\text{UHPRP (linear)} / \text{TRP (linear)}$

23. Upper Hem.Total Radiated Pwr (dBm) $\text{UHTRP(dBm)} = 3\text{dB} + \text{UHPRP(dBm)}$

24. LHPRP / TRP Ratio (dB) $\text{LHPRP (dBm)} - \text{TRP (dBm)}$

25. LHPRP / TRP Ratio (%) $\text{LHPRP (linear)} - \text{TRP (linear)}$

26. Lower Hem. Total Radiated Pwr(dBm) $\text{LHTRP(dBm)} = 3\text{dB} + \text{LHPRP(dBm)}$

27. Front/Back Ratio (dB)

$$U(\theta=0^\circ) \text{ (dB)} - U(\theta=180^\circ) \text{ (dB)} \text{ or } U(\theta_{\text{max}},\varphi_{\text{max}}) \text{ (dB)} - U(180^\circ - \theta_{\text{max}},180^\circ + \varphi_{\text{max}}) \text{ (dB)}$$

RFxpert Software
Glossary

- 28. N/A
- 29. N/A
- 30. N/A
- 31. N/A
- 32. Boresight Phi (°) = The phi angle of the peak EIRP Φ_{max}
- 33. Boresight Th. (°) = The theta angle of the peak EIRP θ_{max}
- 34. Maximum Power (dBm) $Max(U)(dBm)$
- 35. Average Power (dBm)

$$[U(\theta=0^\circ)(linear) + U(\theta=90^\circ)(linear) + \sum_{\substack{\theta=1.8^\circ \\ \text{including } 90^{0+} \text{ and } 90^{0-}}}^{88.2^\circ} \sum_{\varphi=0^\circ}^{356.4^\circ} U(\theta, \varphi)(linear)]/9902 \rightarrow$$

- 36. Max/Min Ratio (dB) $Max(U)(dBm) - Min(U)(dBm)$
- 37. Max/Avg Ratio (dB) $Max(U)(dBm) - Average Power (dBm)$
- 38. Min/Avg Ratio (dB) $Min(U)(dBm) - Average Power (dBm)$
- 39. Average Gain (dBi) $TRP(dBm) - Pin(dBm)$
- 40. N/A
- 41. N/A
- 42. N/A
- 43. N/A

Regulatory Compliance

Safety and Regulatory Information

- Read all of the instructions listed here and/or in the user manual before you operate this device. Give particular attention to all safety precautions. Retain the instructions for future reference.
- This device must be installed and used in strict accordance with manufacturer's instructions, as described in the user documentation that is included with this device.
- User must comply with all warning and caution statements in the instructions. Observe all warning and caution symbols that are affixed to this device.
- To prevent shock or fire hazard, do not expose this device to rain or moisture. The device must not be exposed to dripping or splashing. Do not place objects filled with liquids or chemicals on the device.
- This device was qualified under test conditions that included the use of the specified cables, between system components. To ensure regulatory and safety compliance, use only the provided power and interface cables and install them properly.
- Different types of cord sets may be used for connections to the main supply circuit. Use only a main line cord that complies with all applicable device safety requirements of the country of use.
- Installation this device must be in accordance with national wiring codes and confirm to local power company instructions and guidelines.
- Do not overload outlets or extension cords, as this can result in a risk of fire or electric shock. Overloaded AC outlets, extension cords, frayed power cords, damaged or cracked wire insulation, and broken plugs are dangerous. They may result in a shock or fire hazard.
- Route power supply cords so that they are not likely to be walked on or pinched by items placed upon or against them. Pay particular attention to cords where they are attached to plugs and convenience receptacles, and examine the point where they exist from the device.
- Place this device in a location that is close enough to an electrical outlet to accommodate the length of the power cord.
- Place the device to allow for easy access when disconnecting the power cord of the device from the AC wall outlet.
- Do not connect the plug into an extension cord, receptacle, or other outlet unless the plug can be fully inserted with no parts of blades exposed.
- Place the device on a stable surface.
- It is recommended that the customers install an AC surge protector in the AC outlet to which this device is connected. This is to avoid damaging the device by local lightning strikes and other electrical surges.
- Postpone installation until there is no risk of thunderstorm or lightning activity in the area.
- Do not cover the device or block the airflow to the device with any other objects. Keep the device away from excessive heat and humidity and keep the device free from vibration and dust.
- Wipe the device with a clean, dry cloth. Never use cleaning fluid or similar chemicals. Do not spray cleaners directly on the device or use forced air to remove dust.

RFXpert Software Regulatory Compliance

- Do not use this product near water: for example near a washbowl, or a laboratory sink.
- Do not open the device. Do not perform any servicing other than that contained in the installation and troubleshooting instructions. Refer all servicing to qualified service personnel.
- This device should not be used in an environment that exceeds 40° C and lower than 15° C.

FCC Class B Notice

This device complies with Part 15 of the FCC Rules. Operation is subject to the following two conditions:

- This device may not cause harmful interference.
- This device must accept any interference received, including interference that may cause undesired operation.

Note: This equipment has been tested and found to comply with the limits for a Class B digital device, pursuant to Part 15 of the FCC Rules. These limits are designed to provide reasonable protection against harmful interference in a residential installation. This equipment generates uses and can radiate radio frequency energy and, if not installed and used in accordance with the instructions, may cause harmful interference to radio communications. However, there is no guarantee that interference will not occur in a particular installation. If this equipment does cause harmful interference to radio or television reception, which can be determined by turning the equipment off and on, the user is encouraged to try to correct the interference by one or more of the following measures:

- Reorient or relocate the receiving antenna
- Increase the separation between the equipment and receiver
- Connect the equipment into an outlet on a circuit different from that to which the receiver is connected
- Consult the dealer or an experienced radio/television technician for help

Modifications: Any modifications made to this device that are not approved by EMSCAN Corporation may void the authority granted to the user by the FCC to operate this equipment.

Changes or modifications not expressly approved by the party responsible for compliance could void the user's authority to operate the equipment.

Pursuant to Part 15.21 of the FCC Rules, any changes or modifications to this product not expressly approved by party responsible for compliance might cause harmful interference and void the FCC authorization to operate this product.

CE mark

RFxpert conforms the following standards or other normative documents:

- Electromagnetic emissions:
(Council Directive 2004/108/EC–EN61326-1:2006. EN55011:2007/A2:2007, EN61000-3-2: 2006, EN61000-3-3:1995/A1:2001)
- Electromagnetic immunity:
(Council Directive 2004/108/EC–EN61326-1:2006 IEC61000-4-2: 1995/A1/A2:2000, IEC61000-4-3:2002, IEC61000-4-4:2004, EN61000-4-5:1995/A1:2001, EN61000-4-6:1996/A1:2001, IEC61000-4-11:2004)
- Safety:
(Council Directive 2006/95/EC-IEC/EN 61010.1)
- Marks of Compliance



Note:

The product must use a CE compliant Client Computer, CE compliant Network Analyzer, CE compliant Base Station Emulator, CE compliant Signal Source and Power Meter, and CE compliant Power supply to ensure system level CE compliance.

Notes



#1, 1715-27 Avenue NE
Calgary, AB T2E 7E1
Canada

Tel: +1-403-291 0313
Fax: +1-403-250 8786

www.emscan.com